



DDMMSP Brick Saw

**DRY BRICK SAW
OWNER'S MANUAL &
OPERATING INSTRUCTIONS**



CAUTION:
Read all safety and
operating instructions
before using this
equipment

Enter the Serial Number of your new saw in the
space below. The Serial Number is located on the
left side of the blade guard.

SERIAL NUMBER:

INTRODUCTION and TABLE OF CONTENTS

INTRODUCTION:

We at DDM, Inc. want to congratulate you on selecting the DDMMSD Dry Brick Saw. We are certain that you will be pleased with your purchase. DDM, Inc. takes pride in producing the finest products in the industry.

Operated correctly, your DDMMSD should provide you with years of quality service. In order to help you, we have included this manual. This owners manual contains information necessary to operate and maintain your DDMMSD safely and correctly. Please take a few minutes to familiarize yourself with the DDMMSD by reading and reviewing this manual.

If you should have questions concerning your DDMMSD, please feel free to call our friendly customer service department at: 800 654-7224.

TABLE OF CONTENTS

	Page
SAFETY:	
Safety Messages	3
Damage Prevention Message	3
General Safety Precautions and Hazard Symbols	3
California Proposition 65 Message	5
Electrical Requirements and Grounding Instructions	6
Safety Label Locations	8
Brick Saw Specific Warnings	8
Product Specifications	8
UNPACKING AND ASSEMBLY	
Unpacking	9
Contents	9
Transport	9
Assembly	10
SETUP, ADJUSTMENT AND OPERATION	
Setup	11
Adjustment and Operation	13
Cleanup	16
MAINTENANCE AND TROUBLESHOOTING	
Maintenance	17
Troubleshooting	19
EXPLODED VIEW AND PARTS LIST	
Exploded View	21
Parts List	22
ACCESSORIES, ORDERING and RETURN INSTRUCTIONS	
Accessories	24
Ordering Information	25
Return Material Policy	25
Packaging Instructions	25
Authorized Service Centers	25

Manual Part No. 158168

Revision No. 2

UNPACKING, TRANSPORT and ASSEMBLY

Read and follow all safety, operating and maintenance instructions. Failure to read and follow these instructions could result in injury or death to you or others. Failure to read and follow these instructions could also result in damage and/or reduced equipment life.

SAFETY MESSAGES:

Safety messages inform the user about potential hazards that could lead to injury, death and/or equipment damage. Each safety message will be preceded by one of the following (3) three words that identify the severity of the message.

⚠ DANGER

Not following instructions **WILL** lead to **DEATH** or **SERIOUS INJURY**

⚠ WARNING

Not following instructions **COULD** lead to **DEATH** or **SERIOUS INJURY**

⚠ CAUTION

Not following instructions **CAN** lead to injury

DAMAGE PREVENTION AND INFORMATION MESSAGES:

A Damage Prevention Message is to inform the user of important information and/or instructions that could lead to equipment or other property damage if not followed. Information Messages convey information that pertains to the equipment being used. Each message will be preceded by the word NOTE, as in the example below.

NOTE:

Equipment and/or property damage may result if these instructions are not followed.

GENERAL SAFETY PRECAUTIONS AND HAZARD SYMBOLS:

In order to prevent injury, the following safety precautions and symbols should be followed at all times!

Safety Precautions:

KEEP GUARDS IN PLACE.



In order to prevent injury, keep guards in place and in working order at all times.

REMOVE ADJUSTING KEYS AND WRENCHES.

Form a habit of checking to see that keys and adjusting wrenches are removed from the power tool before it is turned on.

KEEP WORK AREA CLEAN.

Cluttered work areas and benches invite accidents.

DO NOT USE IN DANGEROUS ENVIRONMENTS.

Do not use power tools in damp or wet locations nor expose them to rain. Always keep the work area well lighted.

KEEP CHILDREN AWAY.

All visitors and children should be kept a safe distance from work area.

MAKE THE WORKSHOP KID PROOF.

Make the workshops kid proof by using padlocks, master switches or by removing starter keys.

DO NOT FORCE THE TOOL.

A power tool will do a job better and safer operating at the rate for which it was designed.

USE THE RIGHT TOOL.

Do not force a tool or an attachment, to do a job that it was not designed to do.

UNPACKING, TRANSPORT and ASSEMBLY

USE THE PROPER EXTENSION CORD.

If using an extension cord make sure it is in good condition first. When using an extension cord, be sure to use one heavy enough to carry the current your product will draw. An undersized cord will cause a drop in line voltage that will result in a loss of power and overheating. TABLE 1, Page 7 shows the correct AWG size to use depending on cord length and nameplate ampere rating. If in doubt, use the next heavier gage. The smaller the gage number, the heavier the cord.

WEAR PROPER APPAREL.

Do not wear loose clothing, gloves, neckties, rings, bracelets, or other jewelry that may be caught in moving parts. Non-slip footwear is recommended. Wear protective hair covering to contain long hair.

ALWAYS USE SAFETY GLASSES.



Safety glasses should always be worn when working around power tools. In addition, a face, dust mask or respirator should be worn if a cutting operation is dusty. Everyday eyeglasses only have impact resistant lenses and may not prevent eye injury—they are NOT safety glasses.

SECURE WORK.

Clamps or a vise should be used to hold work whenever practical. Keeping your hands free to operate a power tool is safer.

DO NOT OVERREACH.

Keep proper footing and balance at all times by not overreaching.

MAINTAIN TOOLS WITH CARE.

Keep tools clean for the best and safest performance. Always follow maintenance instructions for lubricating, and when changing accessories.

DISCONNECT TOOLS.

Power tools should always be disconnected before servicing or when changing accessories, such as blades, bits, cutters, and the like.

REDUCE THE RISK OF UNINTENTIONAL STARTING.



Make sure the trigger switch; locking button is in the RELEASE position before plugging in a power tool.

USE RECOMMENDED ACCESSORIES.

Consult the owner's manual for recommended accessories. Using improper accessories may increase the risk of personal or by-stander injury.

NEVER STAND ON THE TOOL.

Serious injury could occur if a power tool is tipped, or if a cutting tool is unintentionally contacted.

CHECK FOR DAMAGED PARTS.

Before using a power tool, check for damaged parts. A guard or any other part that is damaged should be carefully checked to determine it would operate properly and perform its intended function. Always check moving parts for proper alignment or binding. Check for broken parts and mountings and all other conditions that may affect the operation of the power tool. A guard, or any damaged part, should be properly repaired or replaced.

DIRECTION OF FEED.

Always feed work into a blade or cutter against the direction of rotation. A blade or cutter should always be installed such that rotation is in the direction of the arrow imprinted on the side of the blade or cutter.

NEVER LEAVE A TOOL RUNNING UNATTENDED – TURN POWER OFF.

Do not leave a tool until it comes to a complete stop. Always turn a power tool OFF when leaving the work area, or, when a cut is finished.

UNPACKING, TRANSPORT and ASSEMBLY

Hazard Symbols:

ELECTRICAL SHOCK!



Never touch electrical wires or components while the motor is running. Exposed, frayed or worn electrical motor wiring can be sources of electrical shock that could cause severe injury or burns.

ACCIDENTAL STARTS!



Before plugging the equipment into an electrical outlet, be sure the trigger switch, locking button is in the "RELEASE" position to prevent accidental starting. Unplug the power tool before performing any service operation.

ROTATING OR MOVING PARTS!



Keep hands, feet, hair, and clothing away from all moving parts to prevent injury. Never operate a power tool with covers, shrouds, or guards removed.

⚠WARNING

Sawing and drilling generates dust. Excessive airborne particles may cause irritation to eyes, skin and respiratory tract. To avoid breathing impairment, always employ dust controls and protection suitable to the material being sawed or drilled; See OSHA (29 CFR Part 1910.1200). Diamond Blades improperly used are dangerous. Comply with American National Standards Institute Safety Code, B7.1 and, Occupational Safety and Health Act covering Speed, Safety Guards, Flanges, Mounting Procedures, General Operating Rules, Handling, Storage and General Machine Conditions.

CALIFORNIA PROPOSITION 65 MESSAGE:

⚠WARNING

Some dust created by power sanding, sawing, grinding, drilling, and other construction activities contain chemicals known [to the State of California] to cause cancer, birth defects or other reproductive harm. Some examples of these chemicals are:

- Lead, from lead-based paints
- Crystalline silica, from bricks and cement and other masonry products and
- Arsenic and chromium, from chemically treated lumber

Your risk from these exposures varies depending on how often you do this type of work. To reduce your exposure to these chemicals, work in a well-ventilated area, and work with approved safety equipment, such as those dust masks that are specially designed to filter out microscopic particles.

UNPACKING, TRANSPORT and ASSEMBLY

ELECTRICAL REQUIREMENTS AND GROUNDING INSTRUCTIONS:

In order to prevent potential electrical shock and injury, the following electrical safety precautions and symbols should be followed at all times!

⚠ WARNING



In case of a malfunction or breakdown, grounding provides a path of least resistance for electric current to reduce the risk of electric shock. This tool is equipped with an electric cord having an equipment-grounding conductor and a grounding plug. The plug must be plugged into a matching outlet that is properly installed and grounded in accordance with all local codes and ordinances.

- Do not modify the plug provided – if it will not fit the outlet; have the proper outlet installed by a qualified electrician
- Improper connections of the equipment-grounding conductor can result in a risk of electric shock. The equipment-grounding conductor is the insulated conductor that has an outer surface that is green, with or without yellow stripes. If repair or replacement of the electric cord or plug is necessary, do not connect the equipment-grounding conductor to a live terminal
- Check with a qualified electrician or service personnel if the grounding instructions are not completely understood, or if in doubt as to whether the tool is properly grounded
- Use only 3-wire extension cords that have 3-prong grounding plugs and 3-pole receptacles that accept the tool's plug
- Repair or replace a damaged or worn cord immediately

⚠ WARNING



This tool is intended for use on a circuit that has an outlet that looks like the one shown in Sketch A of Figure 1. The tool has a grounding plug that looks like the plug illustrated in Sketch A of FIGURE 1. A temporary adapter, which looks like the adapter illustrated in sketches B and C, may be used to

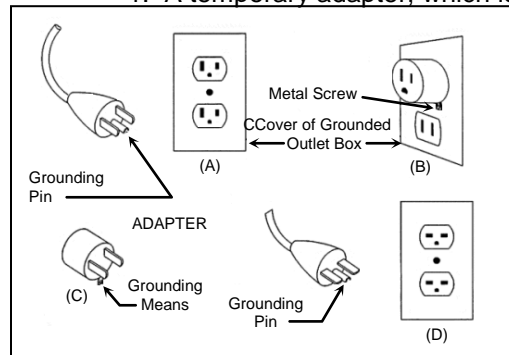

connect this plug to a 2-pole receptacle as shown in Sketch B, if a properly grounded outlet is not available. The temporary adapter should be used only until a properly grounded outlet can be installed by a qualified electrician. The green-colored rigid ear, lug, and the like, extending from the adapter, must be connected to a permanent ground such as a properly grounded outlet box.

NOTE: Use of a temporary adapter is not permitted in Canada.

FIGURE 1

⚠ WARNING



To reduce the risk of electrocution, keep all connections dry and off the ground.

A Ground Fault Circuit Interrupter (GFCI) should be provided on the circuit(s) or outlet(s) to be used for the Brick Saw. Receptacles are available having built-in GFCI protections and may be used for this measure of safety.

When using an extension cord, the GFCI should be installed closest to the power source, followed by the extension cord and lastly, the saw.

UNPACKING, TRANSPORT and ASSEMBLY

⚠ WARNING



To avoid the possibility of the appliance plug or receptacle getting wet, position the Brick Saw to one side of a wall mounted receptacle. This will prevent water from dripping onto the receptacle or plug. A "drip loop," shown in FIGURE 2, should be arranged by the user to properly position the power cord relative to the power source.

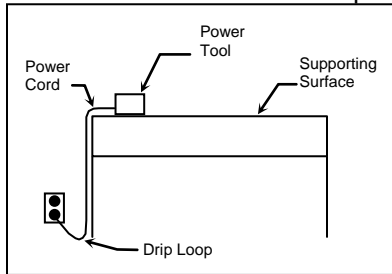

FIGURE 2

The "drip loop" is that part of the cord below the level of the receptacle, or the connector, if an extension cord is used. This method of positioning the cord prevents the travel of water along the power cord and coming in contact with the receptacle.

If the plug or receptacle gets wet, DO NOT unplug the cord. Disconnect the fuse or circuit breaker that supplies power to the tool. Then unplug and examine for presence of water in the receptacle.

⚠ WARNING



Use only extension cords that are intended for outdoor use. These extension cords are identified by a marking "Acceptable for use with outdoor appliances; store indoors while not in use." Use only extension cords having an electrical rating not less than the rating of the product. Do not use damaged extension cords. Examine extension cords before using and replace if damaged. Do not abuse extension cords and do not yank on any cord to disconnect. Keep cords away from heat and sharp edges. Always disconnect the extension cord from the receptacle before disconnecting the product from the extension cord.

To reduce the risk of electrocution, keep all connections dry and off the ground. Do not touch the plug with wet hands.

⚠ WARNING



Use of undersize extension cords result in low voltage to the motor that can result in motor burnout and premature failure. DDM, Inc. warns that equipment returned to us showing signs of being run in a low voltage condition, through the use of undersized extension cords will be repaired or replaced totally at the customers expense. There will be no warranty claim.

To choose the proper extension cord,

- Locate the length of extension cord needed in TABLE 1 below.
- Once the proper length is found, move down the column to obtain the correct AWG size required for that length of extension cord.

As an example, a fifty (50) foot extension cord would require an AWG size of 16.

Extension Cord Minimum Gage for Length				
Volts	Total Length of Cord in Feet			
	25 ft.	50 ft.	100 ft.	150 ft.
120V	AWG 14	AWG 12	AWG Not Recommended	AWG

TABLE 1

UNPACKING, TRANSPORT and ASSEMBLY

PRODUCT SPECIFICATIONS:

The DDMMSM is a versatile lightweight, dry, masonry saw. Operated and used according to this manual, the DDMMSM will provide years of dependable service.

General Description:

The DDMMSM, is engineered as a 14" dry saw, consisting of a powerful 115v motor in a hard plastic case. The saw is capable of cutting brick and masonry up to 8" x 8" x 16" in size; the blade has a five (5) inch cutting depth.

Motor and Weight Specifications:

Motor and Weight specifications for the DDMMSM are listed in Table 2 below.

Voltage	115 v
Amperage	13 A
Frequency	60 Hz
RPM	3,500 rpm
Weight	45 lbs.*

Table 2

Blade Capacity:

The DDMMSM uses a 14-inch diameter segmented dry DDM, Inc. blade with a .115-inch cutting width.

Masonry Types:

The DDMMSM can cut a variety of masonry types including, cinder block, slump stone block, wall brick, paver brick, concrete block and cylinders, roofing tile, marble, granite, decorative rock or almost any other non-ferrous material.

NOTE:

The DDMMSM is not designed to cut plastic or ferrous (metals) material.

Spring Assisted Cutting Head:

The DDMMSM is designed with a spring assisted Cutting Head to allow for easier step cutting. The Cutting Head can be locked in the down position when cutting smaller pieces.

Lockable Trigger Switch:

The DDMMSM is designed with a lockable trigger-operating switch in the handle to allow for ease of operation.

Removable Motor Air Filter:

The DDMMSM is designed with an easy clean motor air filter to extend the life of the motor.

Replaceable Motor Brushes:

The DDMMSM is designed with replaceable motor brushes to extend operating life.

*Without Movable Cutting Table

UNPACKING, TRANSPORT and ASSEMBLY

UNPACKING:

Your DDMMSP has been shipped from the factory thoroughly inspected. Only minimal assembly is required.

If not already done, remove the DDMMSP from the carton and place it on a flat surface. Remove Strapping. Remove the Accessories box from the main carton and place along side the DDMMSP (Owners Manual is in Accessories Box).

CONTENTS:

In the containers, you will find one (1) DDMMSP, one (1) 14 inch segmented dry diamond blade (or segmented block blade), one (1) movable cutting table, one (1) adjustable cutting guide, one replacement motor air filter, one (1) blade wrench, one (1) shaft wrench, one (1) owner's manual and one (1) warranty card.



DDMMSP



Segmented Dry
Diamond Blade

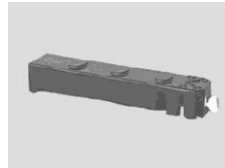

Adjustable
Cutting Guide

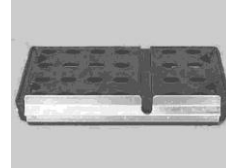

Movable Cutting
Table



Extra Motor
Air Filter



Blade
Wrench



Shaft
Wrench



Owner's
Manual



Warranty
Card

TRANSPORT:

The DDMMSP weighs approximately forty (45) pounds (Without the Movable Cutting Table), making transport easy.

⚠CAUTION Always observe safe lifting practices when lifting the DDMMSP.

NOTE: Lock the Cutting Head in the DOWN position, and remove the Movable Cutting Table when transporting the DDMMSP.

Due to its lightweight construction, the DDMMSP is designed to be carried by the durable aluminum frame. Simply lock the spring assisted cutting head in the DOWN position, grasp the frame by the lower front and upper back cross members, lift and transport the DDMMSP to the desired work location

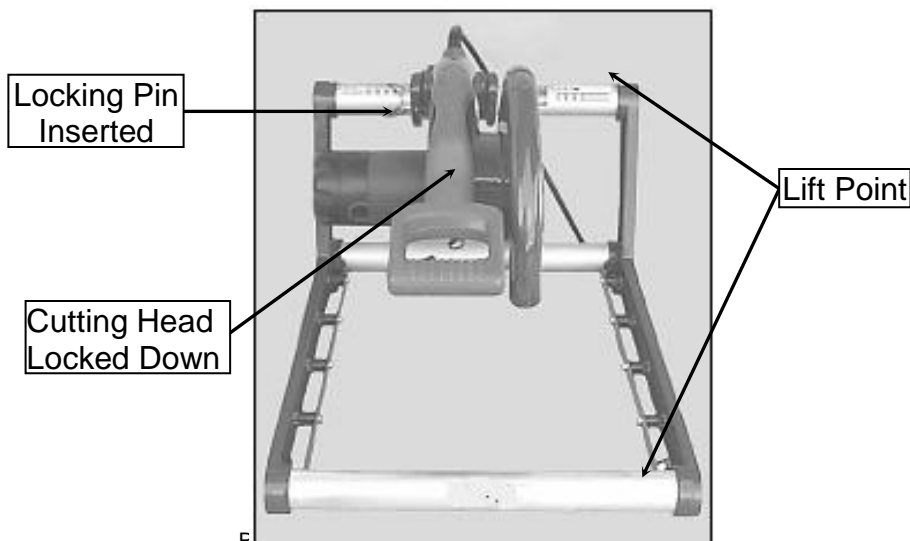

UNPACKING, TRANSPORT and ASSEMBLY

ASSEMBLY:

Follow the assembly instructions to prepare your DDMMSP for operation.

1. Movable Cutting Table Installation:

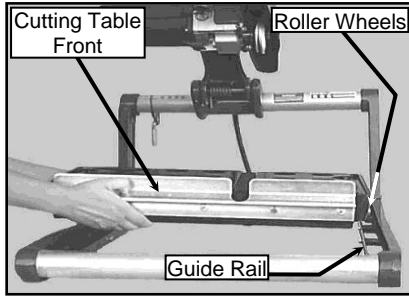

(A)
Position Movable Cutting Table

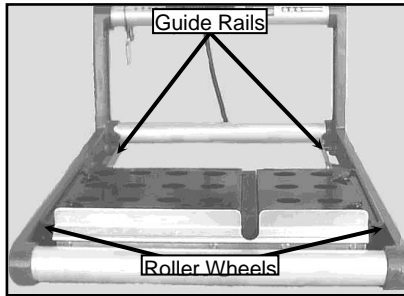

(B)
Seat Roller Wheels on
Guide Rails

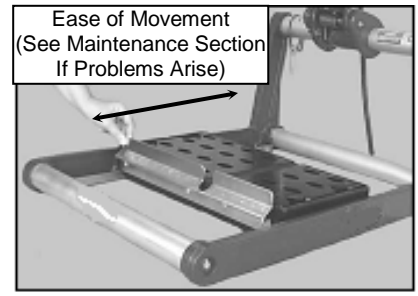

(C)
Verify Correct Seating

2. Adjustable Cutting Guide Installation:

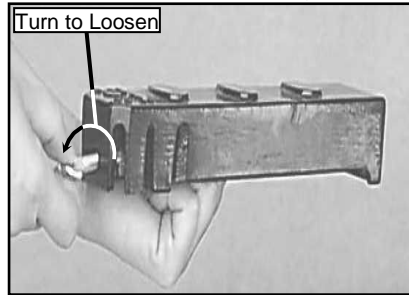

(A)
Loosen Thumbscrew

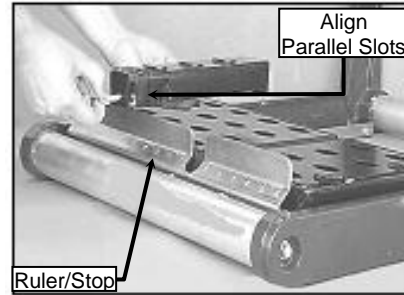

(B)
Position Adjustable Cutting Guide

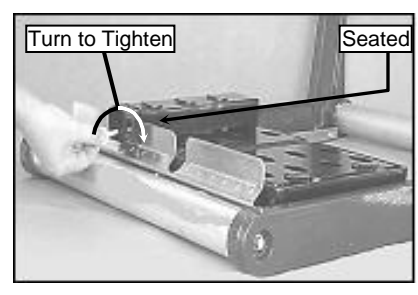

(C)
Seat and Tighten
Adjustable Cutting Guide

3. Diamond Blade Installation:

NOTE: When installing the Retaining Screw, do not "cross-thread" and DO NOT over tighten the screw.

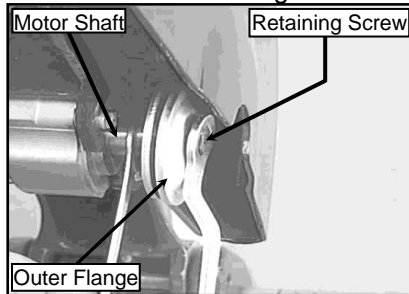

(A)
Identify Retaining Screw
and Outer Flange

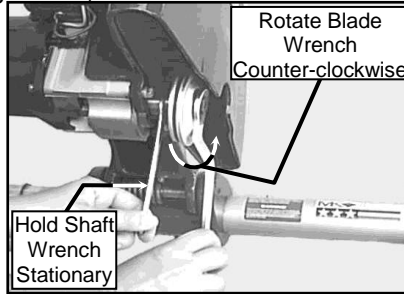

(B)
Remove Retaining Screw
and Outer Flange

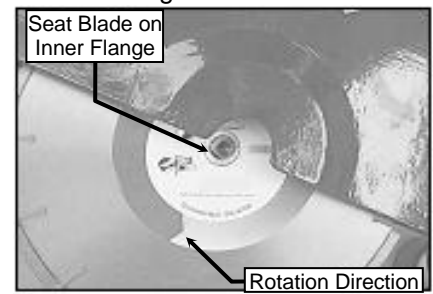

(C)
Install and Seat Blade –
Verify Rotation

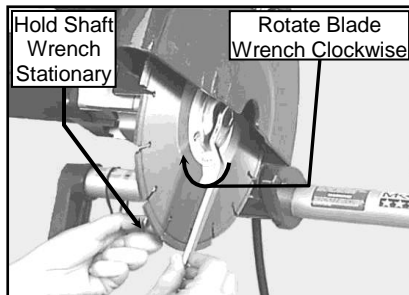

(D)

Install Retaining Screw and Outer Flange - Tighten
Revision 11/00, Effective Date November 1, 2000

SETUP, ADJUSTMENT and OPERATION

SETUP:

⚠CAUTION

- Before powering or starting, check for damage that could prevent this equipment from proper operation or performing its intended function. Check for binding and alignment of moving parts. Check for damaged, broken, or missing parts.
- Verify the trigger switch, locking button is in the "RELEASE" position.
- Before connecting the DDMMS to a power supply, be sure the voltage, cycle and phase of the job site power source meet the requirements of TABLE 3

VOLTAGE:	115v
CYCLE:	60hz
PHASE:	single phase

TABLE 3

- If using an extension power cord, make sure the length and wire gauge corresponds to the requirements listed in TABLE 1 on page 7. An extension power cord that is too small in wire gauge (diameter), or too long in length, will cause the motor to overheat and could cause premature failure.
- Use an approved Ground Fault Circuit Interrupter (GFCI)
- Do not cover the motor vents as this could lead to motor overheating.

Portable Generator:

If using a portable generator to provide power, ensure the generator meets the following minimum requirements:

8 kW 120/240 volts 66.7/33.3 amps Single Phase

Pre-start Inspection:

The pre-start inspection should be performed before beginning any job.

NOTE: In order to avoid breaker tripping, a 20-amp circuit breaker should be used.

⚠CAUTION If the Diamond Blade shows signs of fatigue cracking, replace the blade before starting work.

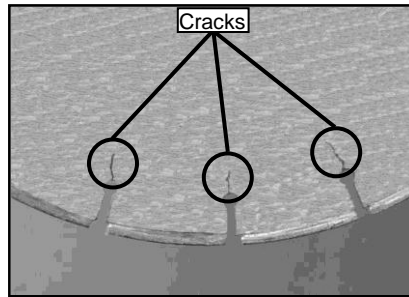

(A)

Inspect Blade for Damage – Verify Blade Correct for Material Being Cut

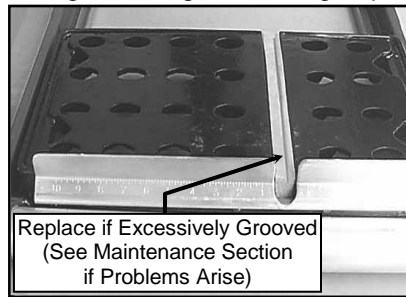

(B)

Inspect Wooden Strip for Excessive Grooves

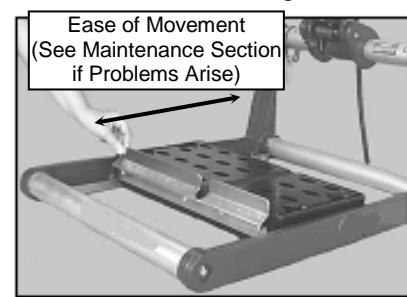

(C)

Movable Cutting Table Moves Freely

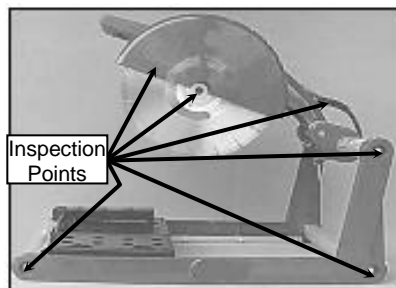

(D)

Inspect for Damage

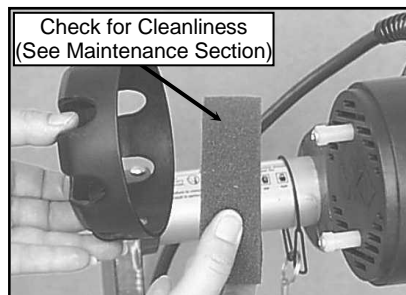

(E)

Inspect Motor Air Filter for Cleanliness

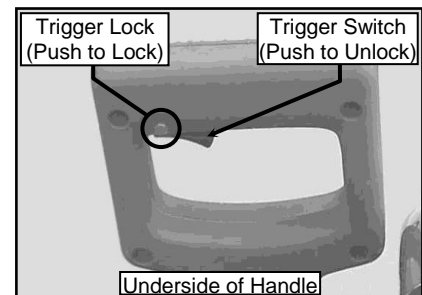

(F)

Verify Trigger Switch Unlocked

SETUP, ADJUSTMENT and OPERATION

⚠CAUTION If an extension cord is used, first verify it meets the requirements of TABLE 1 (page 9). Plug the DDMMSF into the extension cord; plug the extension cord into a GFCI. Finally, plug the GFCI into the power source in that order.



(G)
Plug GFCI into DDMMSF

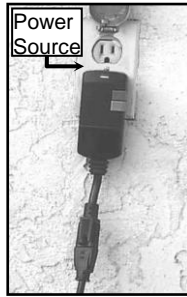

(H)
Plug GFCI into Power Source

SETUP, ADJUSTMENT and OPERATION

ADJUSTMENT AND OPERATION:

1. Cutting Setup:

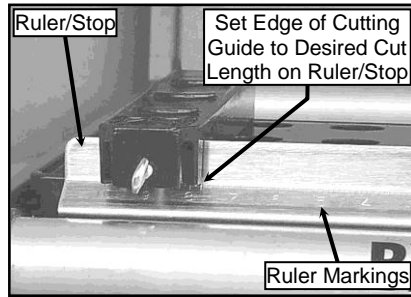

(A)
Set Adjustable Cutting Guide

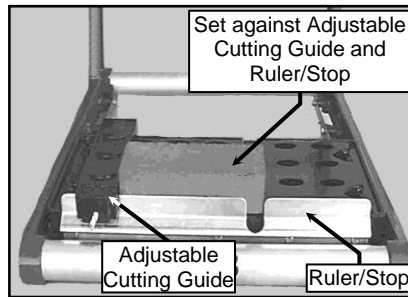

(B)
Position Masonry Piece

⚠CAUTION DO NOT FORCE the blade to cut, it will do the job better and safer at rate for which it was designed.

2. Step Cuts:

A Step Cut is performed when a series of small cuts of increasing depth are used to complete a single cut. Step Cuts are used for large objects or for hard objects such as Firebrick and Pavers.

- NOTE:
1. Step Cutting is the preferred cutting method for all cuts.
 2. When cutting hard material Step Cutting should always be used.
 3. Step Cutting will extend the life of the Diamond Blade.

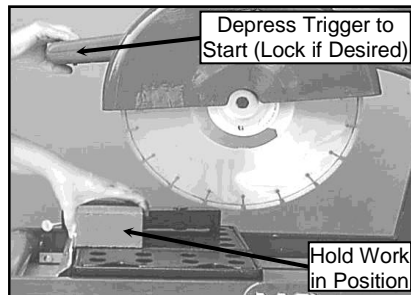

(A)
Step Cut Setup

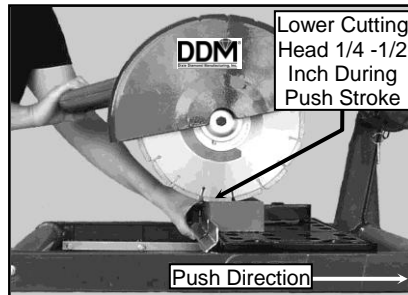

(B)
Step Cut "Push" Stroke

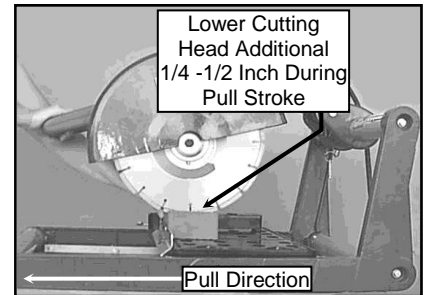

(C)
Step Cut "Pull" Stroke

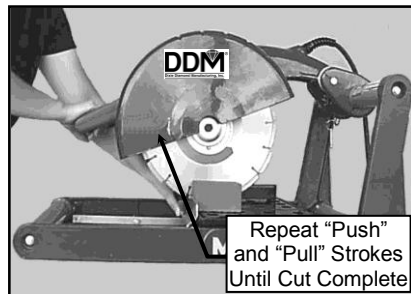

(D)
Repeat Steps B and C
Until Cut Complete

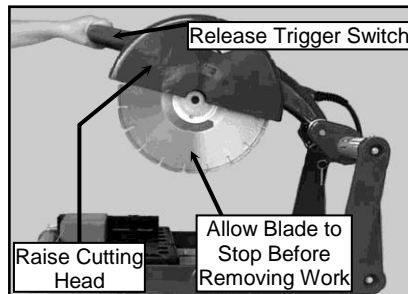

(E)
Cutting Complete

SETUP, ADJUSTMENT and OPERATION

3. Chop Cutting:

A Chop Cut is performed by cutting completely through an object in one pass.

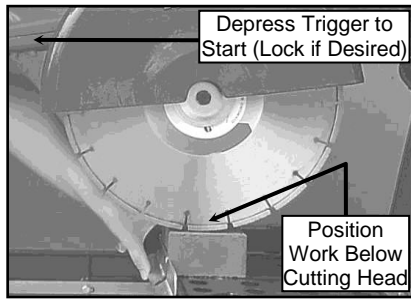

(A)
Chop Cut Setup

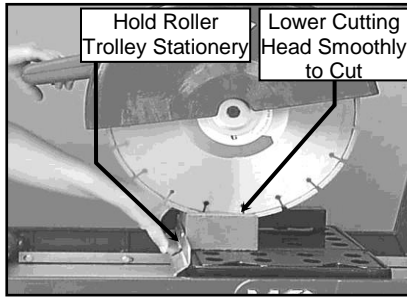

(B)
Lower Cutting Head to Begin Cutting

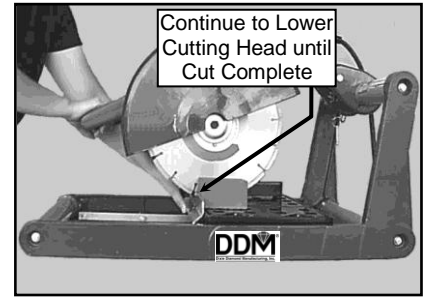

(C)
Continue Lowering Head until Cut Complete

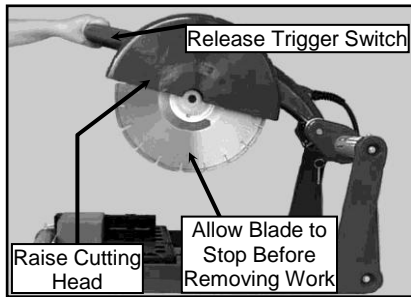

(D)
Cutting Complete

4. Cutting with the Cutting Head Locked Down:

This method is preferred when cutting small objects.

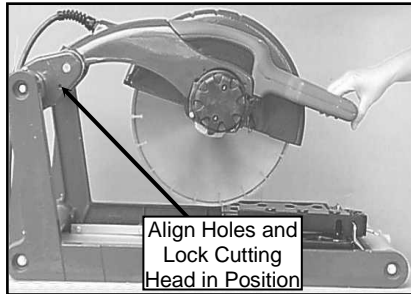

(A)
Lock Cutting Head in the Down Position

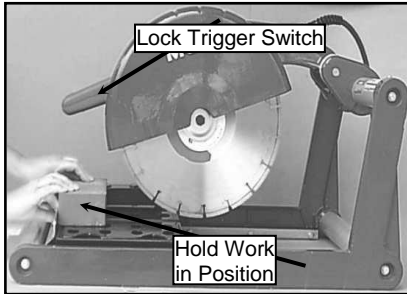

(B)
Locked Cutting Head Setup

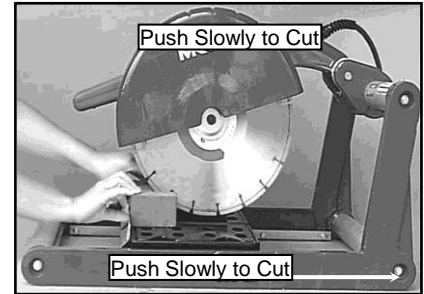

(C)
Slowly Push Piece toward Blade to Begin the Cut

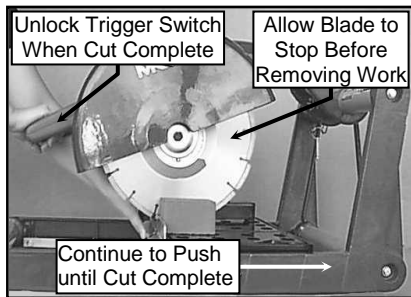

(D)
Continue Pushing Piece into Blade until Cut Complete

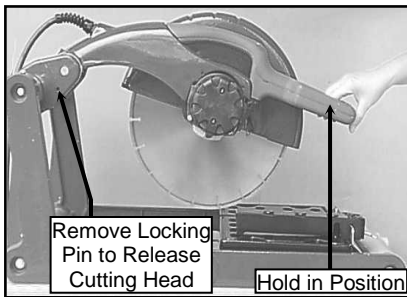

(E)
Cutting Complete

SETUP, ADJUSTMENT and OPERATION

5. Angle Cuts:

Angle Cuts may be performed using the Step Cut, Chop Cut or the Locked Cutting Head cutting methods. The following is utilizing the Locked Cutting Head method.

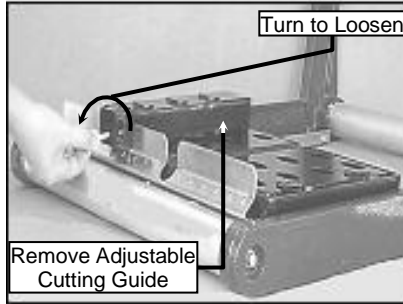

(A)
Remove Adjustable Cutting Guide

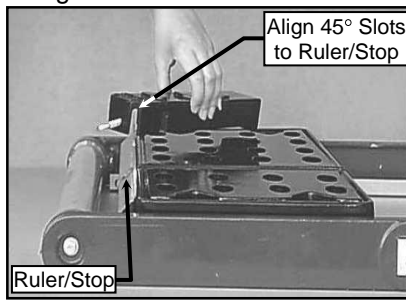

(B)
Reposition Adjustable Cutting Guide

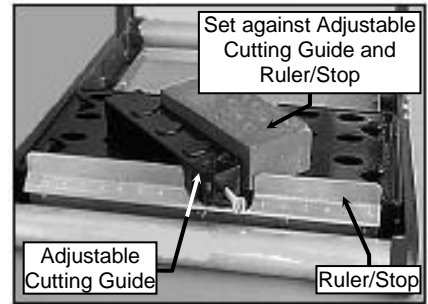

(C)
Position Adjustable Cutting Guide

⚠CAUTION DO NOT FORCE TOOL, it will do the job better and safer at the rate for which it was designed.

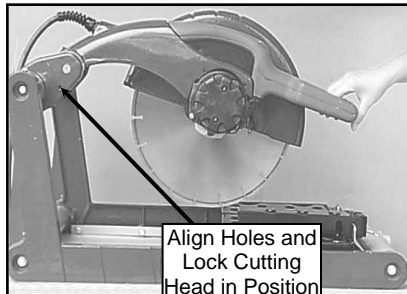

(D)
Lock Cutting Head in the Down Position

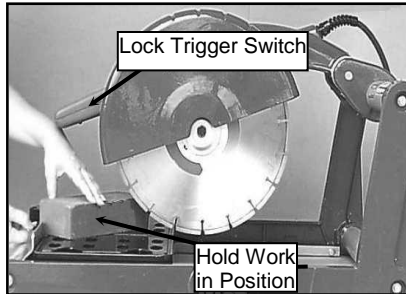

(E)
Locked Cutting Head Setup

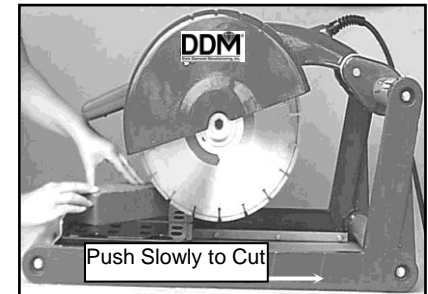

(F)
Slowly Push Piece toward Blade to Begin the Cut

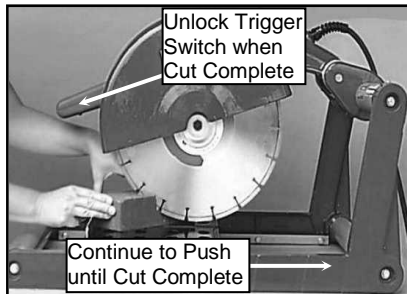

(G)
Continue Pushing Piece into Blade until Cut Complete

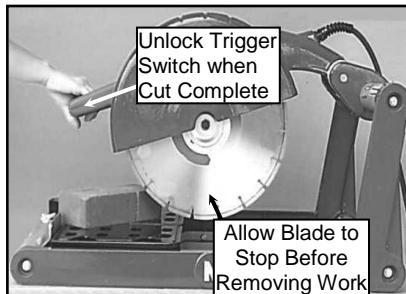

(H)
Cutting Complete

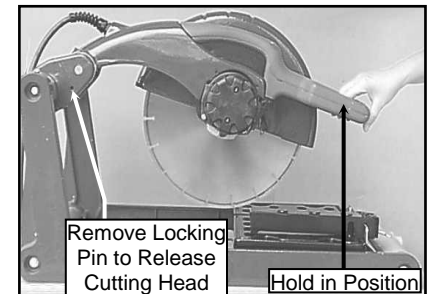

(I)
Release Cutting Head

SETUP, ADJUSTMENT and OPERATION

6. Cleanup:

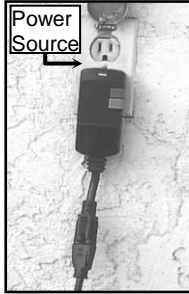

(A)
Unplug GFCI from Power Source

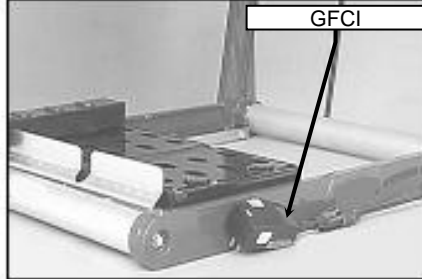

(B)
Unplug GFCI from DDMMS

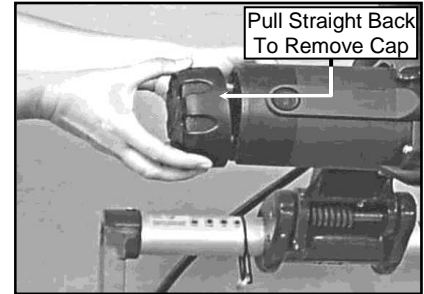

(C)
Remove Motor Filter Cap



▲WARNING Always wear eye protection when using compressed air.

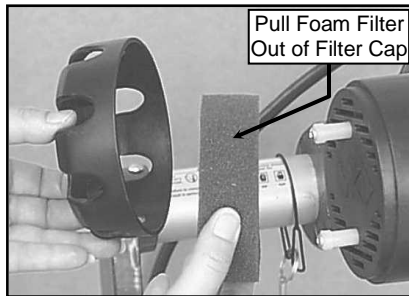

(D)
Remove Filter from Filter Cap



(E)
Clean Filter by Tapping on Hard Surface or using Compressed Air

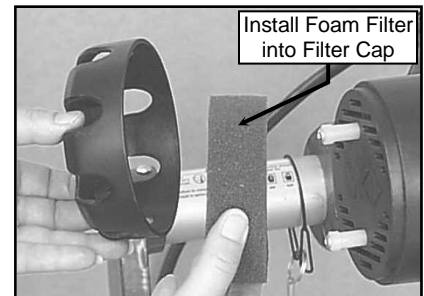

(F)
Reinstall Filter into Filter Cap

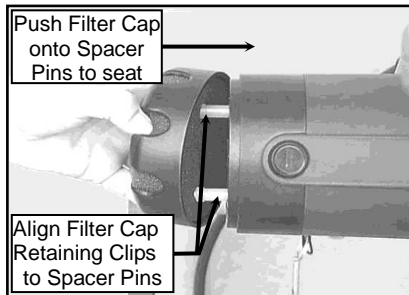

(G)
Install Motor Filter Cap onto Motor

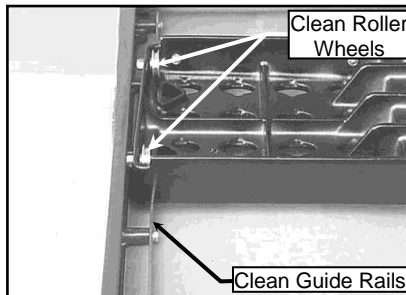

(H)
Clean the Movable Cutting Table Roller Wheels and Guide Rails



(I)
Clean Remainder of DDMMS

MAINTENANCE AND TROUBLESHOOTING

MAINTENANCE:

1. General Maintenance:

The following maintenance should be performed following each use. Use Light oil, such as WD-40 or 3 in 1 when lubricating parts.

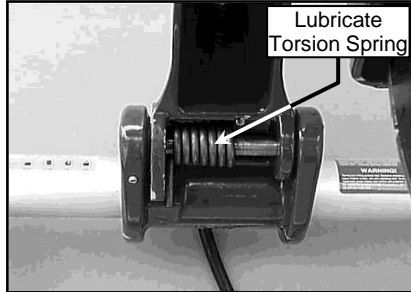

(A)
Lubricate Cutting Head
Torsion Spring

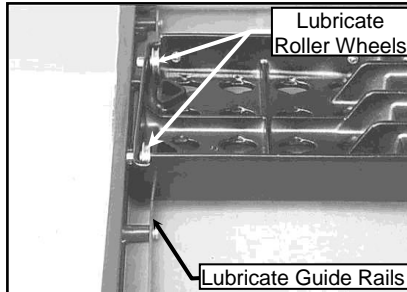

(B)
Lubricate Movable Cutting Table
Roller Wheels and Guide Rails

2. Monthly Maintenance:

The following should be performed monthly. Items should be lubricated as directed.

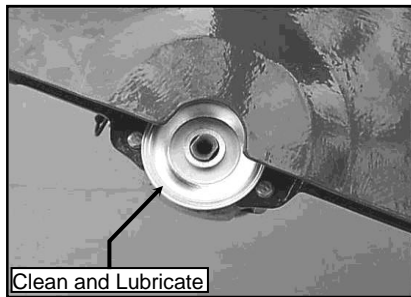

(A)
Clean and Lubricate Inner Flange
and Motor Shaft

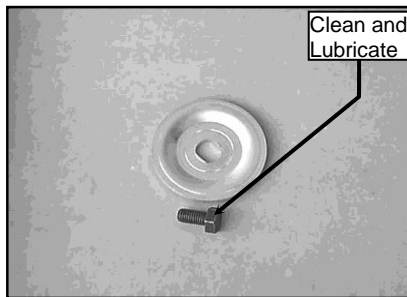

(B)
Clean and Lubricate
Blade Retaining Screw

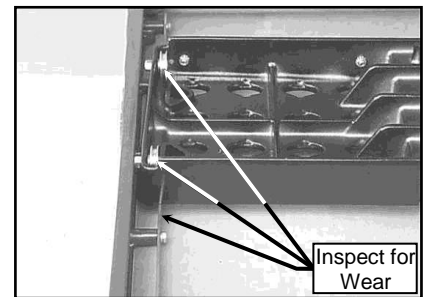

(C)
Check Roller Wheels and
Guide Rails for Wear

NOTES:

3. Motor Brush Change-out:



⚠ **WARNING** Disconnect the tool before servicing and when changing accessories, such as blades, bits, cutters, and the like.



(A)
Disconnect the DDMMS

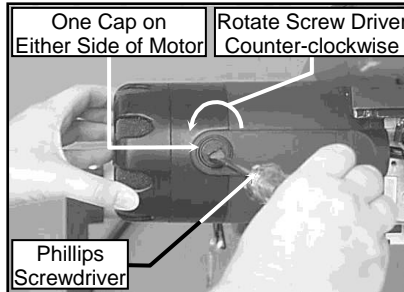

(B)
Locate and Remove One Motor Brush Cap

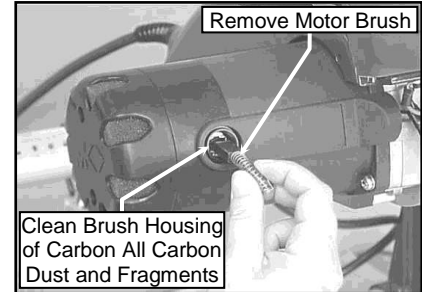

(C)
Remove Motor Brush and Clean Brush Housing

NOTE: When installing motor brushes, care must be taken to ensure the spring end is straight before installing the Motor Brush Cap.

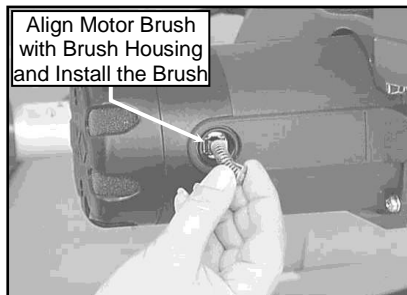

(D)
Align and Install New Motor Brush

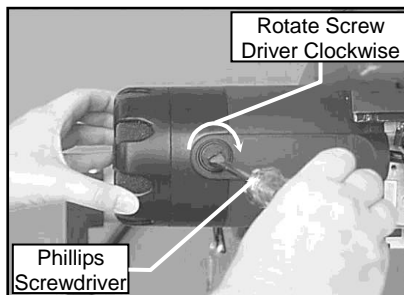

(E)
Install Motor Brush Cap

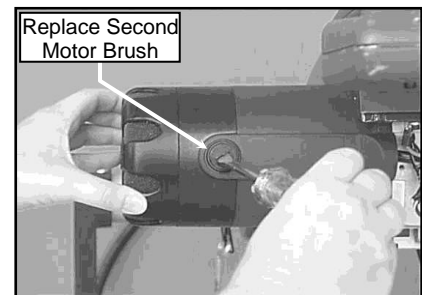

(F)
Install the Second Motor Brush
(Repeat Steps B to E)

NOTES:

TROUBLESHOOTING:

⚠WARNING Verify the Lockable Switch is unlocked and the saw is disconnected from the power source before performing any troubleshooting procedure.

1. Motor Stops Turning:

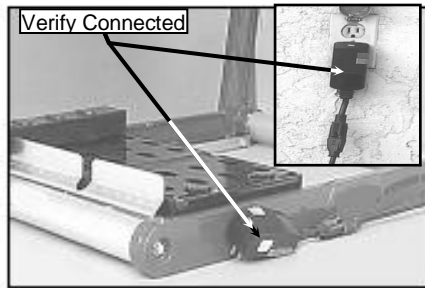

(A)
Verify all Plugs Fully Connected
If Connected, go to Step B

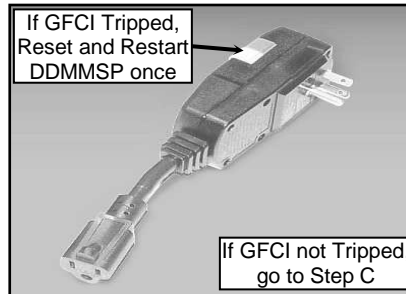

(B)
Check Ground Fault Circuit Interrupter (GFCI) Tripped

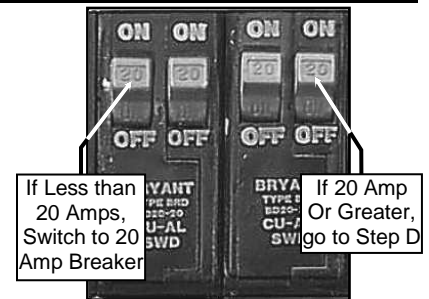

(C)
Verify Circuit Breaker is 20 Amp or Greater

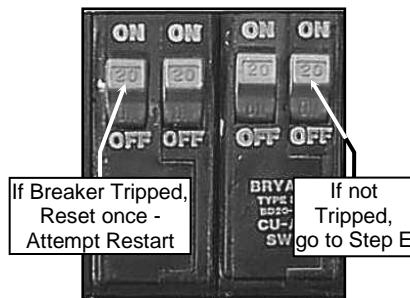

(D)
Verify Circuit Breaker Not Tripped

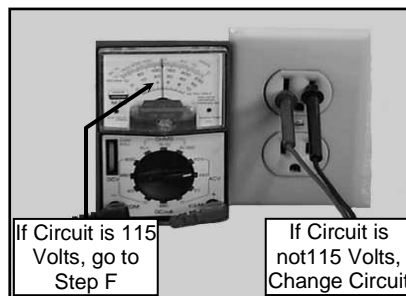

(E)
Verify Source Voltage is 115 Volts

Return to DDM, Inc. for Repair

(F)
Return to DDM, Inc.

2. Blade Will Not Cut Properly:

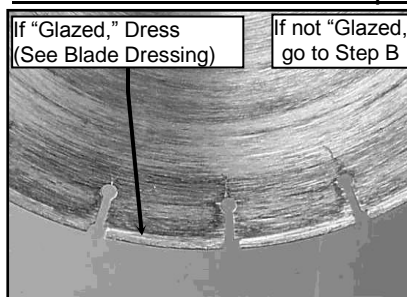

(A)
Check for Smoothness or "Glazing"

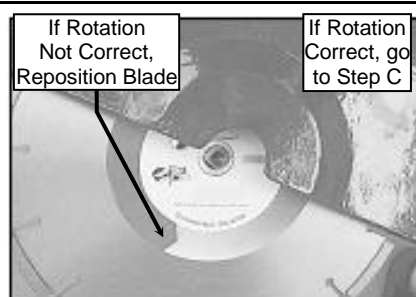

(B)
Check for Proper Rotation

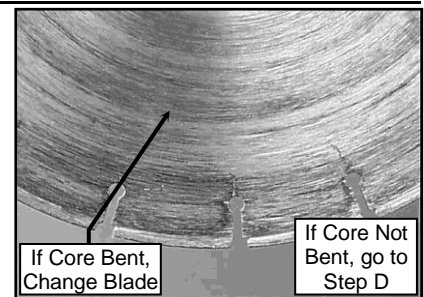

(C)
Ensure Blade Core Not Bent



(D)
Verify Blade Correct for Material Being Used

Return to DDM, Inc. for Repair

(E)
Return to DDM, Inc.

EXPLODED VIEW AND PARTS LIST

EXPLODED VIEW:

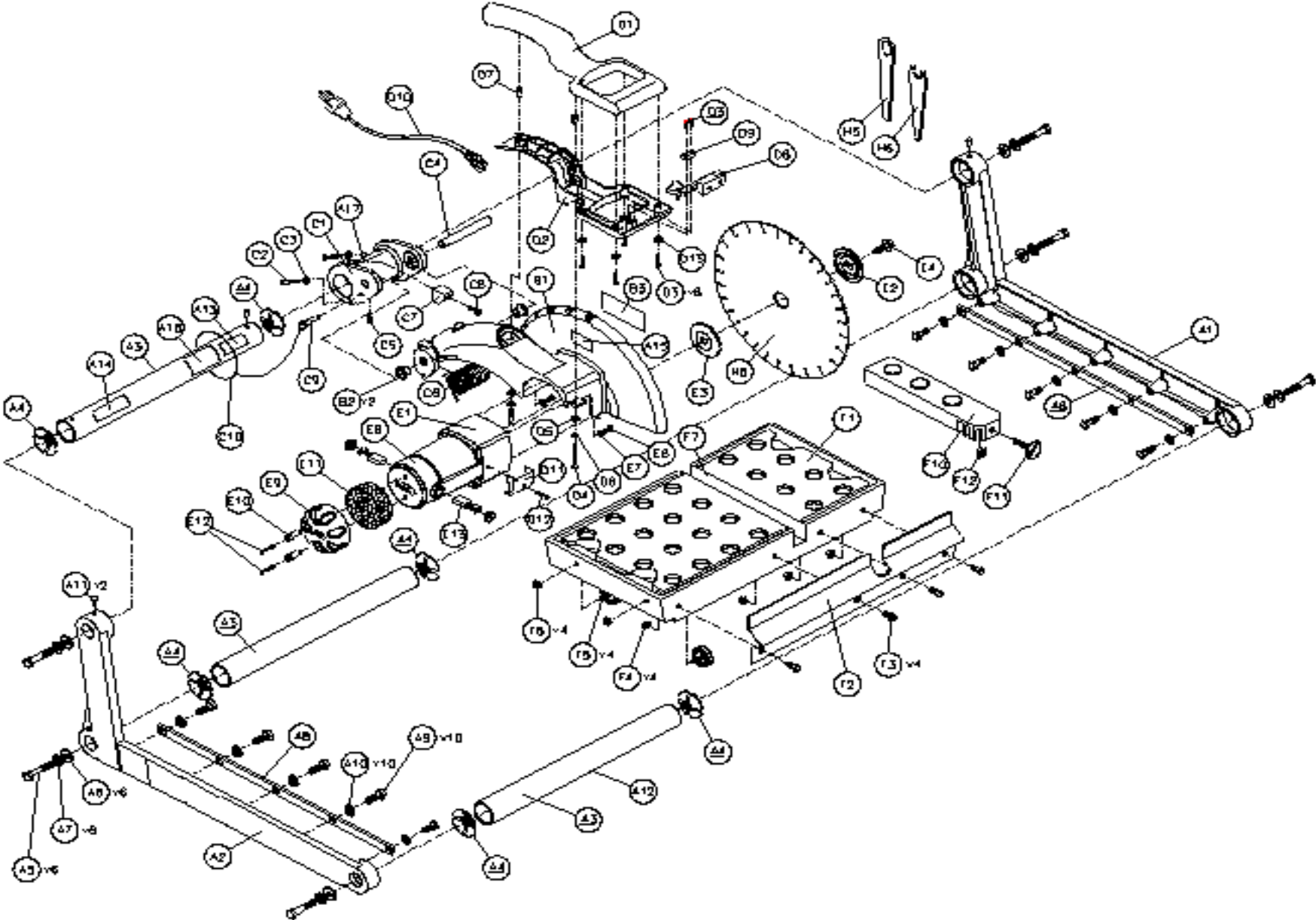

EXPLODED VIEW AND PARTS LIST

PARTS LIST:







Item	Description	Qty	DDM p/n
A	Assembly, Frame, Right	1	n/a
A1	Casting, Frame, Right	1	157367
A2	Casting, Frame, Left	1	157369
A3	Support, Horizontal Frame	3	157384
A4	Tube Connector, ¼-20	6	157930
A5	Screw, ¼-20 x 1 ½ Hex Head Cap	6	151914
A6	Washer, ¼ SAE Flat	6	151915
A7	Washer, ¼ Split Lock	6	152591
A8	Strap, Table Guide Rail	2	157383
A9	Screw, ¼-20 x ¾, Hex Head Cap	10	152370
A10	Washer, ¼ Split Lock	10	152591
A11	Drive Stud, Round Head Grooved #16 (¼) x ½	2	158071
A12	Label, Adhesive "DDM"	1	157959
A13	Label, Safety Caution	1	155576
A14	Label, DDM USA	1	154334
A15	Tag, Serial, Brick Saw	1	158096
A16	Label, Prop 65	1	154337
A17	Label, Warning, Extension Cord	1	155672
B	Assembly, Arm, Motor Mount	1	n/a
B1	Casting, Arm, Motor Mount	1	157599
B2	Bushing, Nylon Flange	2	157932
B3	Label, Adhesive "DDMMSP"	1	157958
C	Assembly, Pivot Clamp	1	n/a
C1	Casting, Pivot Clamp	1	157593
C2	Screw, ¼-20 x 1 ¼ Socket Hd. Cap	2	154683
C3	Washer, ¼ Split Lock	2	152591
C4	Pin, Pivot Ø.625 x 5.6	1	157645
C5	Screw, Set ¼-20 x ¼ Cup Point	1	157528
C6	Spring, Torsion	1	157702
C7	Stop Block	1	158226
C8	Screw, ¼-20 x 5/8, Socket Hd Cap	1	152587
C9	Pin, Detent w/ Pull Ring	1	157933
C10	Lanyard	1	158072
D	Assembly, Handle & Switch	1	n/a
D1	Handle, Upper	1	157874
D2	Handle, Lower	1	157875
D3	Screw, M3.5 x 12mm	8	158156
D4	Screw, ¼-20 x ¾, Socket Hd. Cap	2	152587
D5	Washer, ¼ SAE, Flat	2	151915
D6	Washer, ¼ Split Lock	2	152591
D7	Insert, Expansion, ¼-20 Standard	2	158147
D8	Switch, Trigger	1	157934
D9	Plate, Screw, Switch Mounting	1	157876
D10	Cord, AC Power 120V	1	157935
D11	Cover, Wire	1	157880
D12	Screw, # 6-32 x 1 ¼, Socket Flat Head	1	158160
D13	Washer, #6 Flat SAE	5	158231
E	Assembly, Motor	1	n/a
E1	Motor, AC 115 Volt / 13 Amp, 3500 RPM	1	157801
E2	Flange, Outer	1	158105

ACCESSORIES, ORDERING and RETURN INFORMATION

Item	Description	Qty	DDM p/n
E3	Flange, Inner	1	158106
E4	Screw, M10 – 1.5 x 20mm Hex Flange	1	158107
E6	Screw, M6-1 x 20mm Hex Head Cap	4	158158
E7	Washer, M6 Split Lock	4	158159
E8	Cap, Motor	1	157877
E9	Cap, Motor Filter	1	157878
E10	Spacer Pin, Cap Screw	2	157879
E11	Filter Element	1	157729
E12	Screw, #6 x 1 ½, Combo Head Pan, Tapping	2	158157
F	Assembly, Table	1	133082
F1	Casting, Table	1	158144
F2	Stop, Rule	1	134387
F3	Screw, ¼-20 x ¾ Hex Head Cap	4	152370
F4	Nut, ¼-20, Hex w/ External Tooth Washer	4	153941
F5	Wheel, Roller	4	133090
F6	Nut, 5/16-18, Hex w/ External Tooth Washer	4	151051
F7	Wood Strip, Table Insert	1	156427
F8	Screw, #8 x 1 Pan Head Phil.	2	151047
F10	Casting, Squaring Arm	1	231276
F11	Screw, 5/16-18 x 1 ½, Thumb	1	151155
F12	Nut, 5/16-18 Square	1	151156
H	Assembly, Accessory Pack	1	n/a
H5	Wrench, Blade Nut	1	158109
H6	Wrench, Shaft	1	158110
H7	Extra Filter Element	1	157729
H8	Blade, DDM-HP100, Dry Cutting 14", Segmented Brick	1	157957
H8-A	Blade, DDM-DSLPU700, Dry Cutting 14", Segmented Block	1	157944
	Owner's Manual	1	158168

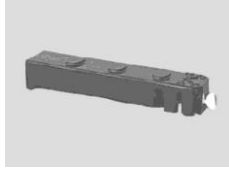
ACCESSORIES, ORDERING and RETURN INFORMATION

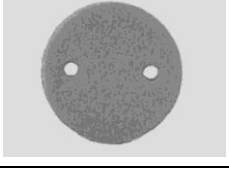
ACCESSORIES:

ITEM	NUMBER	DESCRIPTION	
1.	HP10014110	DDM-HP100, Dry Cutting 14" Segmented Brick Blade	
2.	DSLPU70014115	DDM-DSLPU700, Dry Cutting 14" Segmented Block Blade	
3.	231276	Adjustable Cutting Guide	
4.	133090	Roller Wheel	
5.	156427	Protective Wooden Strip	
6.	157729	Motor Air Filter	
7.	152610	Ground Fault Circuit Interrupter	
8.	157981	DDMMSP Stand (Stand contains Owners Manual)	

ACCESSORIES, ORDERING and RETURN INFORMATION

ORDERING INFORMATION:

You may order DDM, Inc. products through your local DDM, Inc. distributor or, you may order direct from DDM, Inc..

When ordering direct from DDM, Inc., please have the following information ready before calling:

- The Model Number of the saw
- The Serial Number of the saw
- Where the saw was purchased and when
- The Part Number for the part(s) being ordered
- The Part Description for the part(s) being ordered

All parts may be ordered by calling toll free to – **800 654-7224** or **770-921-2464** and asking for Customer Service. For technical questions, call – **800 654-7224**.

RETURN MATERIALS POLICY:

To expedite the service relative to the return of a product purchased through DDM, Inc., please observe the following:

NOTE: When returning all items, they must have been purchased within the previous twelve (12) months.

- Have the Model Number of the saw
- Have the Serial Number of the saw
- Have the location of where the saw was purchased
- Have the date when the saw was purchased
- Contact Customer Service for approval to return the item(s)
- Obtain a Returned Goods Number (RGA) authorizing the return
- Follow the packaging instructions in the following section
- Ensure your item(s) are prepaid to the destination

For returned items, call toll free to – **800 654-7224** or **770-921-2464** and ask for Customer Service. For technical questions, call – **800 654-7224** or **770-921-2464**.

PACKAGING INSTRUCTIONS:

- Remove the Blade guard and Support Angle Assembly
- Dry the saw before shipping
- When packing, include the following: DDMMSPP, Diamond Blade, Blade guard and Support Angle Assembly and Adjustable Cutting Guide (Other Accessories are not required)
- Package the unit in its original container or one of comparable size (do not ship the unit partially exposed)
- Ensure all parts are secured in the packaging to prevent moving

AUTHORIZED SERVICE CENTERS:

For quicker repair time, you may contact DDM, Inc. Customer Service, toll free, at – **800 654-7224** or **770-921-2464** for the Authorized Service Center closest to you. For technical questions, call – **800 654-7224**.



Dixie Diamond Manufacturing, Inc.

DDMMSP Brick Saw

BRICK SAW OWNER'S MANUAL & OPERATING INSTRUCTIONS

CALIFORNIA PROPOSITION 65 MESSAGE:

⚠ WARNING

Some dust created by power sanding, sawing, grinding, drilling, and other construction activities contain chemicals known [to the State of California] to cause cancer, birth defects or other reproductive harm. Some examples of these chemicals are:

- Lead, from lead-based paints
- Crystalline silica, from bricks and cement and other masonry products and
- Arsenic and chromium, from chemically treated lumber

Your risk from these exposures varies depending on how often you do this type of work. To reduce your exposure to these chemicals, work in a well-ventilated area, and work with approved safety equipment, such as those dust masks that are specially designed to filter out microscopic particles.

Dixie Diamond Manufacturing, Inc.
205 Buxton Court, Lilburn, GA 30047
800-654-7224
dixiediamond.com