

OWNERS MANUAL



COMPACT CONCRETE SAW

MODEL
DDM13-18



Part Number 159875
Rev. 06/04

TABLE OF CONTENTS

<u>General Safety Instructions</u>	2-4
Safety Messages	2
Hazard Symbols	3
Damage Prevention Messages	4
Safety Label Locations	4
<u>Saw Features</u>	5
Blade Drive System	5
Depth Indicator	5
Tach/Hour Meter	5
Water System	5
<u>Unpacking and Preparation</u>	6
<u>Initial Servicing</u>	6-7
Engine Preparation	6
Add Oil	6
Add Fuel	6
Mounting the Blade	7
Front Pointer Alignment	7
<u>Sawing Operations</u>	8-12
Description of Controls	8
Determination of Sawing Hazards	8
Operation in Enclosed Areas	9
Engine Starting Procedures	9
Pre Start Checklist	9
Maneuvering the Saw	9
Wet Cutting	10
Dry Cutting	10
Aligning the Saw with a Marked Line	10
Starting a Cut	11
Sawing a Straight Line	11
Finishing a Cut	12
Cutting with the Blade on the Left Side	12
Blade Speed and Throttle Setting	13-15
<u>Maintenance:</u>	13
Maintenance Schedule	14
Cleaning	14
Engine	14
Grease Points	14
Controls	15
V-belts	15
Depth Control	15
Water System	15
<u>Trouble Shooting</u>	16
<u>Service Record</u>	17
<u>Parts Listing & Exploded View</u>	18-23
<u>Company Information</u>	24
<u>Warranty Information</u>	back cover



DANGER

The exhaust from this product contains chemicals known to the State of California to cause cancer, birth defects or other reproductive harm.

GENERAL SAFETY INSTRUCTIONS FOR THE DIXIE D-139 CONCRETE SAW

For your safety!

These safety precautions should be followed at all times. Failure to follow these safety precautions could result in injury to yourself and others.

This manual has been prepared to provide complete instructions for operation and maintenance of the Dixie D-139. For additional instruction concerning engine operations and care refer to the engine manufacturers instructions. **Before using this equipment, ensure that the person operating this machine has read and understands all instructions in this manual.** Precaution is the best insurance against accidents. Read and observe all safety precautions.

SAFETY MESSAGES

A safety message informs you about potential hazards that could hurt you or others. Each safety message is preceded by one of the three words: Danger, Warning, or Caution.



You WILL be KILLED or SERIOUSLY injured if you don't follow instructions.



You CAN be KILLED or SERIOUSLY injured if you don't follow instructions.



You CAN be injured if you don't follow instructions.

Additional Information as to the nature of the hazard is provided by the following hazards symbols which appear throughout the manual in conjunction with safety message alert symbols.

HAZARD
SYMBOLS



 EXPLOSIVE FUEL

Gasoline is extremely flammable and its vapors can explode if ignited. Store gasoline only in approved containers, in well-ventilated, unoccupied buildings, away from sparks or flames. Do not fill the fuel tank while the engine is hot or running, since spilled fuel could ignite if it comes in contact with hot parts or sparks from ignition. Do not start the engine near spilled fuel. Never use gasoline as a cleaning agent.



 HOT PARTS!

Engine components can get extremely hot from operation. To prevent severe burns, do not touch these areas while the engine is running or immediately after it is turned off. Never operate the engine with heat shields or guards removed.



 OVER SPEED!

Never tamper with the governor components or settings to increase the maximum speed. Severe personal injury and damage to the engine or equipment can result if operated at speeds above maximum.

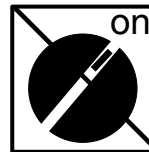

 ACCIDENTAL STARTS!

Before servicing the engine or equipment, always remove the key and disconnect the spark plug lead to prevent the engine from starting accidentally. Ground the lead to prevent sparks that could cause fires. Make sure the equipment is in neutral.



 ROTATING PARTS!

Keep hands, feet, hair, and clothing away from all moving parts to prevent injury. Never operate the engine with covers, shrouds, or guards removed.



 LETHAL EXHAUST GASES!

Engine exhaust gases contain poisonous carbon monoxide. Carbon monoxide is odorless, colorless, and can cause death if inhaled. Avoid inhaling exhaust fumes, and never run the engine in a closed building or confined area.

DAMAGE
PREVENTION
MESSAGES

Other important messages that are designed to help prevent damage to your Dixie D-139 Concrete saw, other property, or the environment are preceded by the word notice.

notice Your Dixie D-139 Concrete Saw or other property could be damaged if you don't follow instructions

SAFETY
LABEL
LOCATIONS

Safety labels are located according to the drawing below. The labels contain important safety information. Please read them carefully. these labels are considered a permanent part of your saw. If a label comes off or becomes hard to read, contact Clipper or your dealer for replacement.

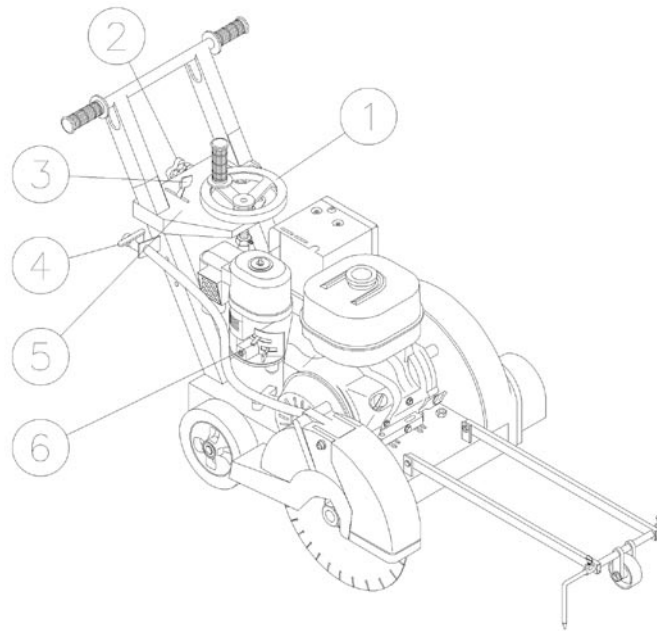

ITEM	LOCATION	DESCRIPTION	PART
LB1	Top of Console	Console Label	227230
LB2	Top of Console	Safety Gear Caution Label	227234
LB3	Back Edge of Console	Depth Lock Label	227231
LB4	Center of Depth Wheel	Clipper Label	227232
LB5	Top of Gas Tank	Hot Surface Caution Label	227235
LB6	Top of Belt Guard	Sparkplug Caution Label	227239
LB7	Top of Gas Tank	Refueling Warning Label	227241
LB8	Top of Gas Tank	California Danger Label	227242
LB9	Top of Gas Tank	Lethal Exhaust Danger Label	227243
LB10	Top of Belt Guard	Belt Tension Caution Label	227238
LB11	Front of Frame	Operating Instructions Label	227244
LB12	Front Edge of Frame	Hands and Feet Caution Label	227240
LB13	Top of Blade Guard	Lift Guard Caution Label	227236
LB14	Top of Belt Guard	Guards in Place Caution Label	227237
LB15	Step on Blade Guard	Blade Failure Warning Label	227264
H16	Top of Console (C-119 and C-139 only)	Cut Depth Label	227233

SAW FEATURES

The Dixie D-139 Concrete Saw is designed for wet or dry, general application sawing. The heavy duty steel, one piece box frame is precision jig welded and reinforced. This precisely reinforced steel construction with balanced weight distribution and ergonomic handlebars assures straight and accurate cutting as well as ease of operations preventing fatigue. The 4-cycle air cooled engine is located for easy access and maintenance. Each solid rubber wheel is mounted on an axle for years of reliable use. The rear axle is rigid, while the front axle pivots causing the blade to be lowered to the desired cutting depth. The positive screw feed provides precision control of the raising and lowering of the blade. The positive screw feed control wheel and all controls are located for easy access and visibility. The following table shows the available models and the features that differentiate them.

MODEL	ENGINE	ADDITIONAL FEATURES
D-139 Premium	Honda GX390 13 hp	cyclone air filter, depth feed indicator, tach/hourmeter

BLADE DRIVE SYSTEM

The blade drive shaft pulleys are connected to both the engine and to the frame mounted blade shaft. Matched v-belts are connected to the pulleys providing engine power to the blade shaft. The 1 inch diameter blade shaft is supported by two self-aligning pillow block bearings. The uniquely designed right and left blade shaft allows for cutting within 2 inches of any wall.

DEPTH INDICATOR (D-139)

The premium models (D-139) include a depth feed indicator mounted on the console, for ease of use and visibility.

TACH/ HOURMETER (D-139)

A digital readout tach/hourmeter is factory installed on the premium models (D-139). When the engine is running, the display will indicate the engines RPM. When the engine is shut off, the display will switch to run time, initially in minutes, and then switching to hours after the first hour of operation.

WATER SYSTEM

The water system of this saw provides water to both sides of the saw blade from inside the blade guard. The saw includes a hose bib hookup and water flow control valve.

UNPACKING,
ASSEMBLY
AND PREPARATION

Your Dixie D-139 has been shipped from the factory fully assembled and requires only minimal service to insure proper machine preparation prior to use. The following instructions should be followed closely. Carefully remove carton, packing materials and the D-139 from the pallet. The saw has been thoroughly inspected and test operated before shipping and should not require any additional adjustments prior to use. Check each item with the illustration making certain all items are accounted for and in good visual condition before discarding any packing materials. If there are any missing or damaged parts, call customer service on our toll free number:

1-(800)-654-7224 for instructions before proceeding further.

CONTENTS OF CARTON: saw, wrench, engine manual, warranty card, owners manual.



 **WARNING**

For your own safety, never start engine until all assembly steps are complete. Read and familiarize yourself with all controls and features of this saw as shown in the illustration before beginning operations.

(Descriptions and illustrations are as accurate as possible at the time of publication. Illustrations may include optional equipment or accessories and may not show all models covered by this literature.)

INITIAL SERVICING

The engine must be thoroughly lubricated, and filled with fuel prior to break-in or use. Refer to manufactures instructions for details of service for the engine. The section on Maintenance in this manual describes the required periodic maintenance required under normal use.

ENGINE
PREPARATION

add
oil

notice The engine is not shipped with oil in the crank case.

To fill the crankcase with oil, place the engine level. In order for this to be accomplished the blade must not be installed, and the depth adjustment must be down (until the engine is level). Refer to the manufacturers instructions for details on the type and amount of oil required. Since the proper amount of oil is important for safe operation, check the oil level of the engine each time you put fuel in the gas tank. Remember that the engine and oil must be warm and your saw must be on level ground to get an accurate reading.

add
fuel

The engine is designed to operate on regular grade unleaded gasoline only. Adding fuel to the tank should be accomplished only when the engine is stopped and cool. Care should be taken to prevent spilling fuel over any part of the console or engine.



 **WARNING**

in the event of a fuel spill do not attempt to start the engine until the spilled fuel has been wiped up and the area is completely dry. When filling the fuel tank do not overfill. Always leave enough area for expansion due to environmental heating.

MOUNTING THE BLADE

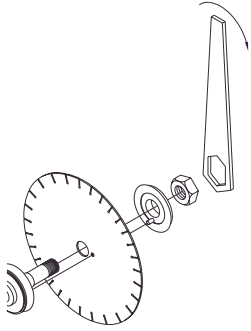

When mounting the blade, locate the direction arrow on the blade and install the blade in the proper orientation. The blade rotates clockwise when viewed from the right side of the saw.

The blade must be properly fitted over the blade shaft and drive pin. The drive pin must project through the hole in the blade and into the flange for proper performance. When tightening the blade shaft nut against the outside of the flange, tighten securely, using approximately 50 ft-lbs of torque. Blade shaft threads are left-hand on the right side of the saw, and right-hand on the left of the saw.

WARNING

DO NOT operate without the proper blade guard covering the blade! **DO NOT** operate the saw with the front of the blade guard raised. Ensure that blade exposure does not exceed 180 degrees during operation.

When installing the blade insure that the blade shaft and flanges are free of dirt and all foreign material before mounting blade on the arbor shaft. Tightening the blade against a uneven surface can cause fracture of an abrasive blade or cause the blade to run out of alignment, which will result in excessive blade wear. Before mounting the blade on the arbor shaft. Tightening the blade against a uneven surface can cause fracture of an abrasive blade or cause the blade to run out of alignment, which will result in excessive blade wear.

FRONT POINTER ALIGNMENT

The front pointer is set in line at the factory. However, the pointer should be checked for proper alignment with the blade after every use. The following are the procedures for aligning the pointer with the blade.

1. Using a straight edge, carefully mark a line 12 feet long on a smooth level concrete surface.
2. Place saw parallel to line. Lower blade and center it over the line.
3. With the blade centered over the line and the saw frame parallel to the line, lower the front pointer assembly and position the pointer over the line.
4. Finally, roll the saw along the entire length of the line. The saw should lead off no more than 6 inches to the left in 12 feet of forward travel. Adjust the pointer in or out if the lead-off is outside this parameter.

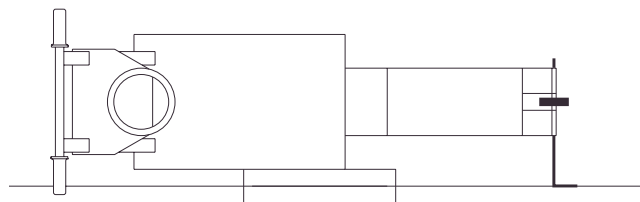

This section of the manual describes the operating procedures, and safety precautions for proper use of this concrete saw. This saw is intended for industrial applications by experienced operators. It is to be operated in conformance with applicable federal, state and local codes or regulations pertaining to safety, air pollution, noise, Etc.

! WARNING

Improper use of this equipment, or improper machine alterations may be dangerous.

It is the operators responsibility to use this machine under safe working conditions and to be fully aware of requirements for operator safety. The operator must be aware of the machine's capabilities and limitations and follow the safety precautions in each section of this manual.

DESCRIPTION OF
CONTROLS

All controls for the D-139 are located for ease of operation.

- 1) the raise lever wheel raises the blade when rotated clockwise, and lowers the blade when rotated counterclockwise.
- 2) the raise/lower wheel lock is engaged when the knob is tightened.
- 3) The throttle control increases engine rpm from slow (idle) at the bottom, to fast (full rpm) at the top.
- 4) The water control lever is off in the vertical position and fully on in the horizontal position. It may be placed at in between settings to regulate the water flow.
- 5) The kill switch is located on the console for quick engine shut-off.
- 6) The choke is located on the engine, by the pull starter, for convenient cold starting.

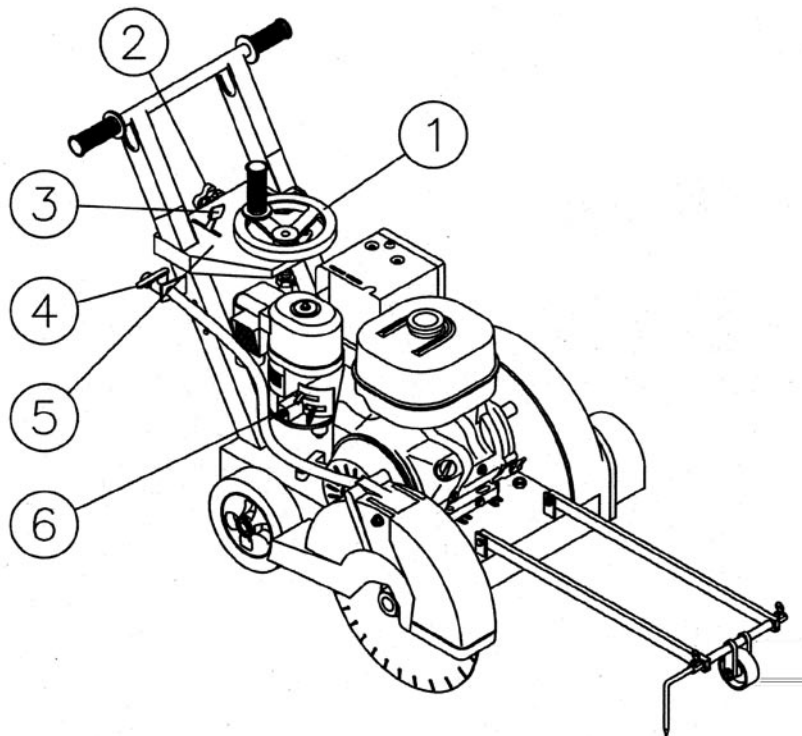

DETERMINATION OF
SAWING HAZARDS

! WARNING

Prior to operation of this machine the operator must determine the existence and location of any subsurface features which may be hazardous or could damage the equipment.(i.e. electric cable, natural gas line, etc.)

OPERATION IN ENCLOSED AREAS



WARNING

The operator is cautioned not to use this equipment within enclosed spaces. Exhaust from the engine in an enclosed space can cause serious illness and possibly death. Ensure that the space is adequately ventilated.

ENGINE STARTING PROCEDURES

pre start checklist

Refer to the engine operating manual for proper engine operation. **Special precautions should be taken during the break-in period as specified by the Engine Manual.**

- check engine oil level. Add oil if low. (See adding oil under Initial servicing section on page 5).
- Check fuel level. Add fuel if low.
- Check cooling air intake and external surfaces of engine. Make sure they are clean and unobstructed.
- Check that the air cleaner components and all shrouds, equipment covers, and guards are in place and securely fastened.
- Choke engine as required for cold starting.
- Move kill switch to the on position. Grasp handle of pull start rope, and pull it out a few inches until it engages. Once pull start is engaged, pull firmly to spin engine. Once engine starts push choke control in. Allow engine to warm up for a few minutes at half throttle. All sawing is done at the correct throttle setting (see the blade speed and throttle setting table).
- To stop engine, move throttle to slow position, turn kill switch to the **OFF** position and wait for all engine movement to stop.

DO NOT TURN OFF WHILE AT FULL THROTTLE!

MANEUVERING THE SAW



notice Raise the blade as high as possible when maneuvering so that the blade will not strike the pavement.

WARNING

The blade is spinning whenever the saw is running.

WET CUTTING

The water used on the blade is to provide coolant during cutting, and to flush the concrete cutting from the cut.

The water hose bib is located below the throttle control on the right side of the saw. After connecting the water supply, turn on the water at the source and use water valve on console to control flow of water to blade. Be sure that both sides of the blade are getting adequate flow of water. The water control adjustment allows the operator to manually control the flow of water to the blade during all operations.

DRY CUTTING

Dry cutting blades have been specially designed for use with walk-behind concrete saws. Ensure that the blade you are using is clearly marked for dry cutting.

notice When dry cutting, it is important to keep the air filter clean. Check the condition of the filter at least every four (4) hours of operation. Clean the pre-filter (wash in soapy water and re-Oil) and change the paper filter as soon as it becomes clogged. Concrete dust is very abrasive, and will quickly damage internal engine parts, causing loss of compression and eventual engine failure

Saw only as deep as the specifications and job conditions require. Remember airflow helps to cool the blade during dry cutting. Cutting too deep with one pass, or exerting excessive forward or side pressure can be dangerous. Step cut in increments of 2 inches(50 mm) or less, for the best results.

If reinforced abrasive blades are used for cured concrete it is usually better to saw only 1" deep per pass, If deeper cuts are required.

Thinner Diamond Blades are especially advantageous when cutting dry.

ALIGNING THE SAW WITH A MARKED LINE

Refer to the figure below. Push the saw forward and approach the marked line at an angle. Stop when the distance from the rear edge of the saw frame to the line (distance A) and the distance from the pointer to the line (distance B) are approximately equal. Lift the rear wheels slightly off the ground by lifting on the handles and swing the rear of the saw around until the pointer is on the line and the saw frame is parallel to it. Do not tilt the saw too far forward to keep the blade from contacting the concrete. The saw should now be aligned with the marked line. Practice will fine tune this method.

Critical to this method of alignment is to ensure that the saw pointer is properly aligned.(see alignment procedures)

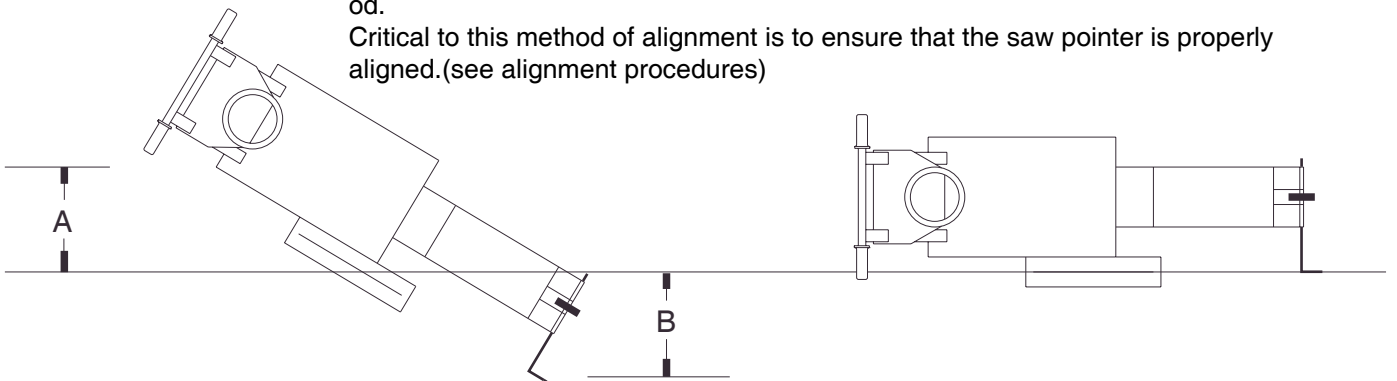

STARTING A CUT

With the engine running at half-throttle. Open the water valve to full open. Check to verify that the water is flowing fully. Adjust the amount of water flowing on the blade to a desired amount.

After adjusting the flow of water increase to proper throttle setting. Lower the blade into the cut by slowly turning clockwise on the depth control wheel. If the water supply is interrupted, **stop cutting immediately.**

When the desired depth of cut is reached, lock the control wheel in position with the depth control locking knob. During cutting, do not exert excessive side pressure on the handle bars to attempt to steer the saw. Use only enough pressure to follow the original marked line.



! WARNING

If the saw should stall for any reason, raise the blade out of the cut before restarting the engine!

When lowering the blade into a partially made cut, the blade must be perfectly aligned within the cut before starting to saw again. **DO NOT** force the blade into the material by lowering the blade too fast.

SAWING A STRAIGHT LINE

The following items should be considered for best economy and efficiency in sawing:

With the water on, engine at the correct throttle setting, and the blade lowered, push the saw forward referring to the pointer alignment.

The saw has a natural tendency to pull towards the side on which the blade is mounted. To assure straight line cutting, apply pressure to the appropriate handle. If excessive pressure is required back off on the forward speed of the saw. If excessive pressure is still required to make the saw travel straight, the saw may need to have the arbor shaft adjusted.

Avoid sudden corrective actions when the saw deviates from the intended line of cutting. Sudden and severe corrections can cause the blade to be damaged or broken.

If the saw stalls in the cut, raise the blade out of the cut and check the blade shaft nut before restarting the engine.



Always raise the blade completely out of the cut before stopping the engine or turning off the water supply.

When sawing joints, be careful not to let the blade cut into the forms.

The forward speed of the saw, during cutting, should be regulated by the operator. Driving the saw too fast while cutting may cause the front wheels to lift causing the blade to cut at uneven depths.

The three controlling factors of cutting economy are:

1. Depth of cut
2. Forward speed of the saw (with the engine at proper throttle)
3. Blade cutting ability

Experimental adjustment of these items, with respect to the aggregate being cut will result in the best cutting economy.

As new blades wear, the cutting ability usually improves. It is best to start at a slow forward speed with a new Blade and work up to a desired cutting speed gradually.

FINISHING A CUT

Raise the blade out of the cut by cranking the depth control wheel counter-clockwise. Raise the blade high enough out of the cut to clear the pavement and allow maneuvering of the saw.

Move the engine throttle to the slow position then turn the kill switch off.

Turn off the water valve.

CUTTING WITH
THE BLADE ON
THE LEFT SIDE
(D-139)

Left side cutting can be easily accomplished by moving the Blade Guard to the left hand side of the saw frame using the following steps:

1. Turn kill switch to off position.
2. Disconnect water hose from blade guard.
3. Remove shaft guard, from the left side of the saw frame and set aside.
4. Remove blade guard from the right side of the saw frame and reassemble on the left side of the saw frame.
5. Reassemble shaft guard on the right side of the saw frame.
6. Connect water hose to blade guard.



When attaching a blade to the left blade shaft, use the outside flange from the right side and the left side nut.

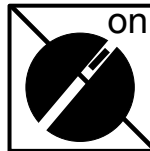

Do not operate saw with any guards removed. Turn kill switch to off position to avoid accidental starts when removing guards.

BLADE SPEED
AND THROTTLE
SETTING

Since diamond blades cut best at specific rim-speeds, blades of different diameters must be turned at different blade shaft rpm's.

On the D-139, the engine pulley and blade shaft pulley are of equal size (1:1 sheave ratio), Therefore engine rpm (as read on the tachometer) and blade rpm are equal.

The D-139 will run either a 14 or 16" blade".

Safe, efficient, economical cutting performance will occur at the engine rpm (as read on the tachometer) stipulated on the following chart.



blade diameter	set engine rpm to
12"	full throttle (3600)
14"	3400-3500
16"	3000-3100



Operating saw blades at rotational speeds greater than those recommended by the manufacturer can cause blade damage and possibly subsequent personal injury.

Never exceed 3600 rpm blade shaft speed.

Periodic maintenance including cleaning, lubrication, tensioning of drive belts, and inspection for wear and damage are routine servicing procedures. Following the procedures as outlined in the following table can prevent serious damage or malfunctioning of the machine and aid in preserving the useful life of saw blades.



! WARNING

Before servicing the saw or engine, always turn the kill switch to the off position.

Item performed at every indicated hours or interval period whichever goes first.	Maintenance Schedule			
	maintenance operation	every 8 hours or daily	25 hours or weekly	100 hours or seasonal
Air Filter	Check	every 4 hours when dry cutting ●		
		when dry cutting ●		
	Change air filter			●
Mainframe	Blade shaft bearings	lube blade shaft bearings at end of operations ●		
	Pivot Bearings		●	
	V-Belts		●	replace ●
Engine	Definitive information on engine maintenance is contained in the Honda or Briggs & Stratton Engine Manual provided separately. Perform all maintenance procedures as recommended by the Engine Manual.			



! WARNING

Shut off the engine before performing any maintenance. If the engine must be run after a maintenance operation make sure the area is well ventilated. The exhaust contains poisonous carbon monoxide gas! Exposure can cause loss of consciousness and may result in death.

CLEANING

Clean the machine daily being careful to remove cutting dust and slurry from the engine cooling fan and air ducts. Failure to perform this operation may prevent smooth control of the saw. Steam cleaning is the preferred method of cleaning.

ENGINE

Engine maintenance and adjustment is necessary to keep the saw in good operating condition. Maintenance operations include oil changes, filter changes, air cleaner, spark plug, fuel filter, etc. Perform all maintenance procedures as recommended by the Honda or Briggs & Stratton Engine Manual provided separately.

For a new engine, it is especially important to change the oil after the first 5 hours of operation. Thereafter, change the oil after every 100 hours of operation as per the engine manufacturers manual.

Note Always dispose of used engine oil and filters in a responsible manner. Follow your community's standards for disposing of these items. Call your local recycling center to find out about recycling engine oil.

GREASE POINTS

There are four (4) grease points (zerk fittings) on the D-139 concrete saw.

The blade shaft bearing grease points need to be serviced at the end of operations on a daily basis. The rest of the grease points require service on a weekly basis (see maintenance schedule).

The two blade shaft grease points are accessed from underneath by tilting the saw back. The raise/lower adjustment tube grease point is accessed from the rear of the saw. The last grease point is located on the flange bearing below the depth adjustment wheel.

See parts lists for grease point locations.

CONTROLS

Stiff or sluggish response of controls must be corrected immediately. Periodically clean and lubricate the throttle cable, the throttle and choke controls. The frequency of this maintenance will depend on the utilization rate and the amount of dust. After performing any maintenance on controls, Saw responsiveness must be checked before the initiation of sawing operations.

V-BELTS

steel straight edge

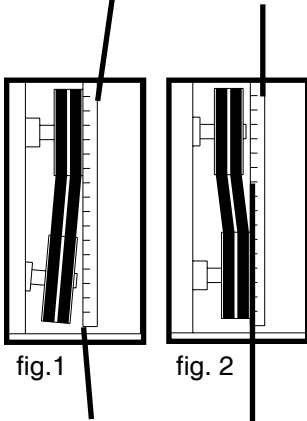

fig.1

fig. 2

Note: gap between steel straight edge and sheave

This machine is equipped with two heavy duty V-belts which are tensioned properly at the factory. These must be re-tensioned after the first half day of operation and periodically thereafter. Adjust to the original tension as set at the factory, which is approximately 1/4 inch of deflection of the center of the belt halfway between the pulley on the motor and the pulley on the blade shaft.

To adjust belt tension, first remove the belt guard. With the belt guard removed, loosen motor mount bolts. Loosen the lock nut and adjust set bolt on the motor tension adjuster until the required belt tension is achieved. Retighten the motor mounting bolts.

The two most common causes of misalignment are shown in the drawings.

a). the engine drive shaft and the blade shaft are not parallel.

FIGURE ONE

b). the pulleys are not located properly on the shafts.

FIGURE TWO



Never make adjustments to belts or pulleys while engine is running.

CAUTION

notice DO NOT OVER TENSION as damage to belts and bearings may occur. Belts that are too loose may slip, resulting in short life and loss of power to the blade shaft. If any belts are worn or damaged, replace the complete set.

The motor mounting plate must be maintained parallel to the frame. Make sure all lock nuts are tightened and retighten the bracket bolts.

See parts list for further v- belt spec. information

DEPTH CONTROL

The depth control (raising screw) consists of a threaded rod which feeds into a steel nut. In order to keep the two parts working smoothly it is necessary to keep the rod free from dirt and sludge as much as possible. Cleaning the threaded rod with a rag after each use will prevent sludge from collecting in the tube assembly and protect the threads. It is a good practice to keep the raising screw threads lubricated, as the slurry generated during cutting will cause premature thread wear.

The bearing used to support the raising screw should be checked after each use to make sure it is turning freely and lubricated. If the bearing requires relubrication a lithium base grease is recommended.

WATER SYSTEM

Check and clean system periodically. Make sure all outlets in the blade guard spray bars are open. Clean if necessary. When storing saw under freezing conditions it is recommended that the water lines be drained to prevent damage.

When trouble occurs, Be sure to check the simple causes which, at first, may seem to obvious to be considered, refer to the table below for problems and their possible causes.

Engine		No fuel	Improper fuel	Dirt in fuel line	Fuse burned out	Incorrect oil level	Dirty air filter	Faulty spark plugs
	will not start	●		●	●		●	●
	Hard starting	●	●	●			●	●
	stops suddenly	●		●		●	●	
	Lacks power		●	●		●	●	●
	operates erratically		●	●			●	●
	Knocks on Pings		●					●
	skips or misfires			●			●	●
	Back fires			●			●	●
	overheats			●			●	
High fuel consumption						●	●	
Other		improper blade for the application		improper belt tension	damage caused by external object			
	reduced blade life	●		●				
	excessive belt wear			●		●		

Parts List

Item	Description	Qty	MK p/n
A1	Owner's Manual, Dixie Diamond Series Concrete Saw	1	159875
A2	Wrench	1	137976
A3	Key, 1/4 Hex	1	156235
B1	Guard, Belt, Dixie Diamond	1	157704-DD
B2	Washer, 5/16 SAE Flat	3	151754
B3	Washer, 5/16 Split Lock	3	151747
B4	Screw, 5/16-18 X 1 Hex Head Cap	1	151743
B5	Screw, 5/16-18 X 3/4 Hex Head Cap	2	151369
B6	Back Plate, Belt Guard	1	157705-DD
B7	Washer, 1/4 SAE Flat	1	151915
B8	Washer, 1/4 split lock	1	152591
B9	Screw, 1/4-20 X 1/2 Hex Head Cap	1	152608
B10	Screw, 3/8-16 X 3/4 Hex Head Cap	1	153527
B11	Washer, 3/8 SAE Flat	1	150923
B12	Washer, 3/8 Split Lock	1	150925
B13	Belt, 3VX280	3	160615
B14	Label, Caution, Belt Tension, 1.5 X 3.0	1	155583
B15	Label, Caution, Guards in Place, 1.5X3.0	1	155587
B16	Label, Caution, Sparkplug	1	155579
C1	Guard, Blade, 16" Rear, Dixie Diamond	1	159949
C2	Guard, Blade, Dixie Diamond 16" Front	1	159879
C3	Fitting, Brass, 1/8 MNPT x 3/8 Barb	1	152501
C4	Screw, 1/2 x 1/2 Socket Head Shoulder, w/ 3/8-16 X 5/8 Thread	2	151753
C5	Washer, 3/8 SAE Flat	4	150923
C6	Washer, 3/8 Split Lock	4	150925
C7	Screw, 3/8-16 X 1 Hex Head Cap	4	152507
C8	Lock, Blade Guard	1	227263
C9	Button, Lock Release	1	227265
C10	Screw, 1/4-20 x 1/2 Hex Head Cap	2	152608
C11	Washer, 1/4 Split Lock	2	152591
C12	Nut, 1/4-20 Hex	2	151893
C13	Pin, 1/4 x 3/4 Roll	1	227273
C14	Label, Caution, Lift Guard, 1.5 X 3.0	1	155586
C15	Label, Blade Failure Warning	1	155588
C16	Blade, 16"	0	reference
D1	Nut, Blade Shaft, 3/4-16 Left Hand	1	155069
D2	Flange, Inner, Left Hand	1	155068
D3	Bearing, 1" Pillow Block	2	155072
D4	Shaft, Blade, Premium	1	157842
D5	Screw, 3/8-16 X 1 1/2 Hex Head Cap	4	153528
D6	Washer, 1/2 SAE Flat	4	150924
D7	Pulley, 3VXx3x3.65x1	1	160613
D8	Screw, 5/16-18 X 1/4 Socket Head Set	2	152607
D9	Key, Square, 1/4 X 1/4 x 1 3/4	1	150796
D10	Flange, Inner, Right Hand	1	157843
D11	Nut, Blade Shaft, 3/4-16 Right Hand	1	157844
D12	Nut, 3/8-16 Hex	4	101188
D13	Washer, 3/8 Split Lock	4	150925
D14	Washer, 3/8 SAE Flat	2	101360
D15	Pin, 3/8 X 1 Type "A" Groove	1	152207
D16	Flange, Outer	1	150732
E1	Carton, Concrete Saw	1	156121
E2	Insert, Carton	2	156123
E3	Pallet, Push Concrete Saw	1	156120

F1	Wheel, Depth Control	1	155156
F2	Screw, 3/8-16 X 1/2 Socket Head Set	1	153710
F3	Knob, Ball, 2", 3.8-16 Insert	1	158519
F5	Screw, 1/2 X 3/4 Socket Head Shoulder w/ 3/8-16 X 5/8 Thread	1	156177
F6	Tube, Depth Control	1	155049
F7	Nut, 3/8-16 Nylock Hex	1	152505
F8	Screw, 3/8-16 X 2 Hex Head Cap	1	153485
F9	Bearing, Flange, w/ zerk fitting	1	155151
F10	Screw, 3/8-16 X 1 1/4 Hex Head Cap	2	150774
F11	Nut, 3/8-16 Nylock Hex	2	152505
F12	Spacer, Depth Control	1	155161
F13	Nut, 3/4-10 Hex	1	155063
F14	Screw, Depth Control	1	155062
G1	Lock, 8-7/8 Depth Control	1	157846
G2	Knob, Depth Lock	1	155845
G3	Thrust Washer	1	155238
G4	Nut, 3/8-16 Nylock Hex	1	152505
H1	Engine, Honda GX390 13hp w/ Cyclone Air Filter	1	155365
H2	Label, Caution, Hot Surface, 1.5 X 3.0	1	155578
H3	Label, Warning, Refueling, 1.5 X 3.0	1	155580
H4	Label, Danger, California, 1.5 X 3.0	1	155581
H5	Label, Danger, Lethal Exhaust, 1.5 X 3.0	1	155582
H6	Screw, 5/16-18 X 1/4 Socket Head Set	2	152607
H7	Key, Square, 1/4 X 1/4 x 1 3/4	1	150796
H8	Pulley, 3VXx3x2.65x1	1	160614
H9	Nut, 3/8-16 Hex	4	101188
H10	Washer, 3/8 Split Lock	4	150925
H11	Washer, 3/8 SAE Flat	7	150923
H12	Plate, Engine Bolt	2	157847
H13	Screw, 3/8-16 X 2 Hex Head Cap	4	153485
H14	Pin, Throttle Control	1	151284
H15	Screw, 8-32 X 3/8 Pan Head Cap	1	156614
H16	Pin, Cotter, 1/16 X 3/4	1	152518
H17	Plug, Plastic, 3/4 Round	1	156615
H18	Deflector, Honda 11/13HP	1	155375
H19	Screw, 6-32 X 1/2 Pan Head Phillips Self-tapping Cap	3	153466
H20	Oil Drain, Sub-assembly Adapter, M12-1.5 x 3/8 Push	1	157577-02
J1	Frame	1	157836-DD
J2	Arm, Tension	1	157848
J3	Washer, 5/16 SAE Flat	2	151754
J4	Nut, 5/16-18 Hex	2	101196
J5	Label, Private Label Serial Number	1	157458
J6	Label, Console	1	159950
J7	Label, Depth Lock, 1.04 X 3.25	1	155577
J8	Label, Operating Instructions, 3.5 X 6.0	1	155584
J9	Label, Caution, Hands and Feet, 2.0 X 4.0	1	155585
K1	Handlebar	1	227102
K2	Handgrip	2	150842
K3	Screw, 3/8-16 X 2 Hex Head Cap	2	153485
K4	Washer, 3/8 SAE Flat	2	150923
L1	Arm, Pointer	1	156544
L2	Pointer	1	155057
L3	Wheel, Pointer, w/ 3/8 X 1/2 X 1 5/8 nylon bushing	1	155066
L4	Screw, 1/4-20 X 3/4 Thumb	2	150991
L5	Clip, Stop	1	157837

L6	Screw, 3/8-16 X 1 1/2 Hex Head Cap	2	153528
L7	Washer, 3/8 SAE Flat	4	150923
L8	Nut, 3/8-16 Nylock Hex	2	152505
M1	Guard, Shaft	1	156307
M2	Washer, 3/8 SAE Flat	3	150923
M3	Washer, 3/8 Split Lock	3	150925
M4	Screw, 3/8-16 X 1 Hex Head Cap	3	152507
M5	Label, Caution, Guards in Place, 1.5X3.0	1	155587
N1	Wire Harness, Standard, Honda	1	158232
N2	Switch, Engine On/Off	1	157851
P1	Screw, 10-24 X 1/2 Pan Head Phillips Cap	2	151744
P2	Nut, 10-24 Clip	2	155407
P3	Assembly, Throttle Head	1	155406
P4	Cable, Throttle, Honda	1	154158
Q1	Truck	1	155048
Q2	Wheel, Rear, 8 X 2 1/4	2	155986
Q3	Wheel, Front, 4 X 1 1/2	2	150830
Q4	Washer, 3/4 SAE Flat	4	153523
Q5	Washer, 3/4 Shim	6	153699
Q6	Screw, 1/2 X 1/2 Socket Head Shoulder, w/ 3/8-16 X 5/8 Thread	2	151753
Q7	Nut, 3/8-16 Hex	2	101188
Q8	Washer, 3/8 Split Lock	2	150925
Q9	Washer, 3/8 SAE Flat	3	150923
Q10	Washer, 1/2 SAE Flat	2	150924
Q11	Pin, Cotter, 1/8 X 1 1/2	4	153861
R1	Fitting, Brass, 1/2 MNPT X Garden Hose Swivel	1	151322
R2	Valve, Shut-Off, 1/2 FNPT X 1/2 FNPT	1	150843
R3	Nut, 1/2 NPT	1	152729
R4	Fitting, Brass, 1/2 MNPT X 3/8 BARB	1	153653
R5	Clamp, 5/8 Hose	2	151198
R6	Hose, 3/8 ID Vinyl	30"	150845
S1	Lifting Bail	1	157745
S2	Screw, 1/2-13 X 1 1/4 Hex Head Cap	4	153532
S3	Washer, 1/2 Split Lock	4	153524
S4	Washer, 1/2 SAE Flat	8	150924
S5	Nut, 1/2-13 Hex	4	151282
T1	Tank, Water	1	156644
T2	Cap	1	156956
T3	Mini Ball Valve, 3/8 MNPT x 3/8 FNPT	1	157898
T4	90° street elbow, 3/8 nylon	1	157895
T5	Quick Disconnect Tube Coupling, 3/8 skt.	1	158079
T6	Quick Disconnect Tube Coupling, 3/8 plug	1	158080
T7	Tee, 3/8 Hose Barb, Brass	1	156646
T8	Hose, 3/8 I.D. Vinyl	3'	150845
T9	Clamp, 3/8 Hose	4	151198
T10	Slide Adjustment, Strap, Water Tank	2	158095
T11	Assy., Strap Water Tank	1	158094
T12	Water Tank Installation Instructions	1	157852-IS

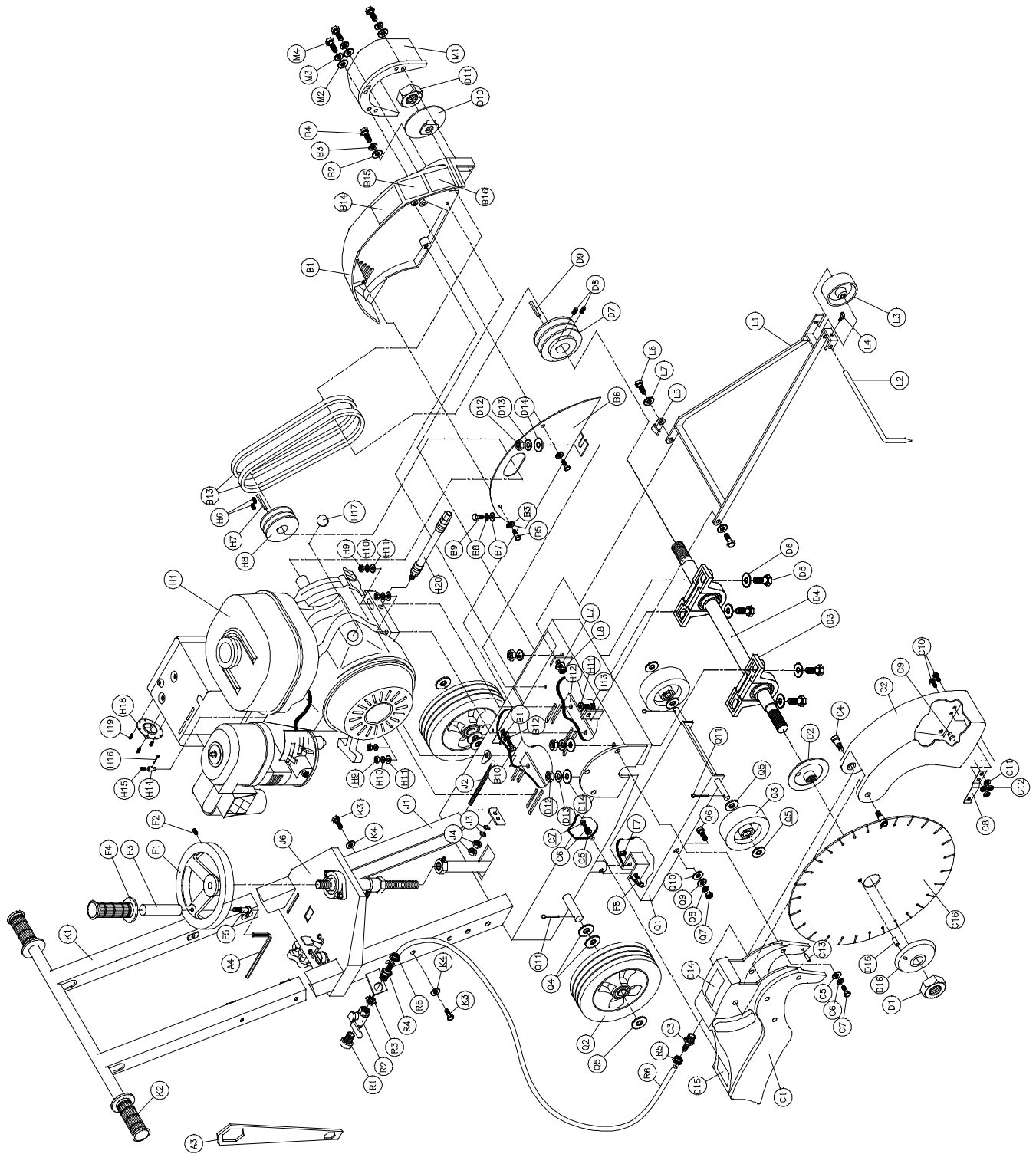

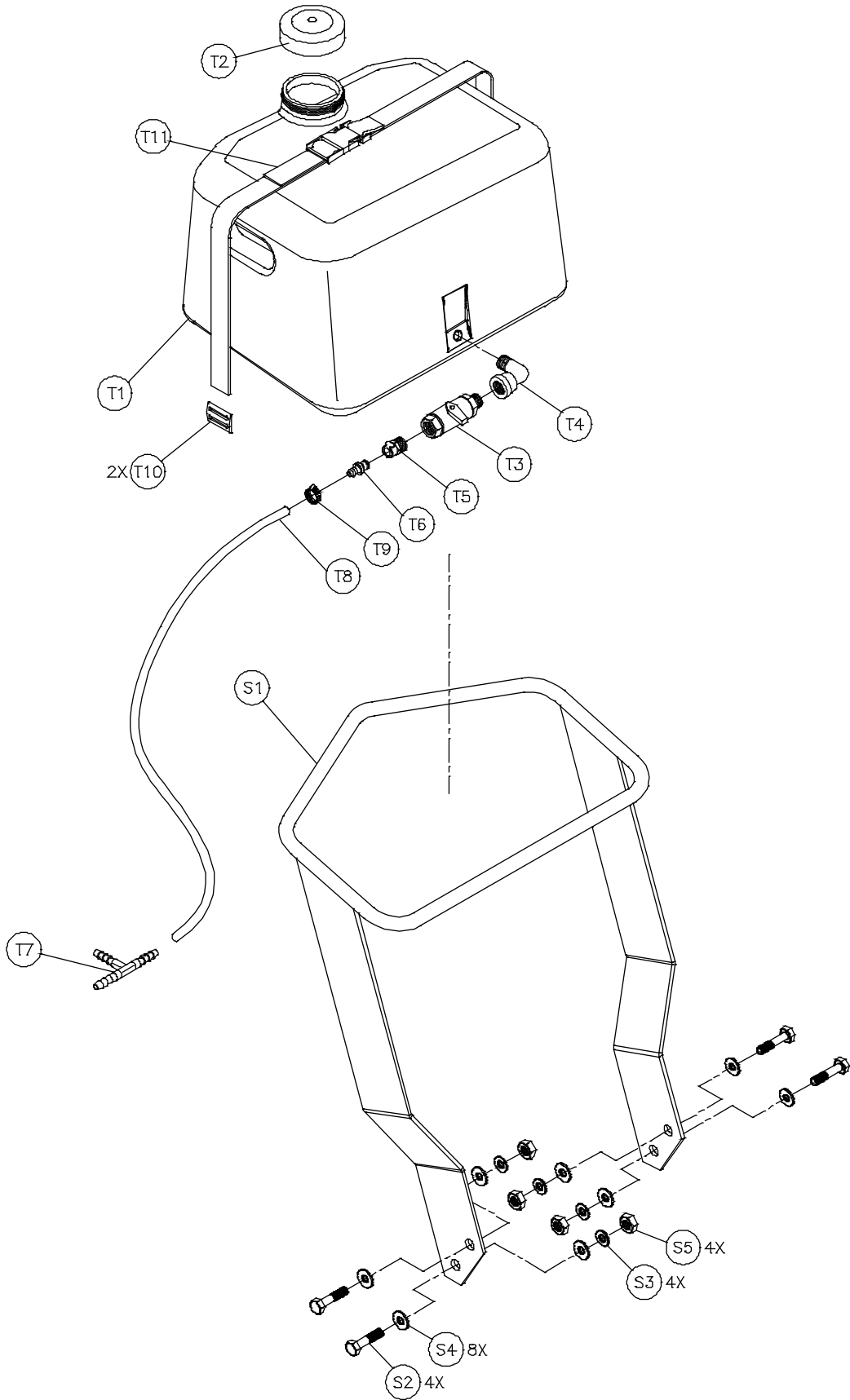

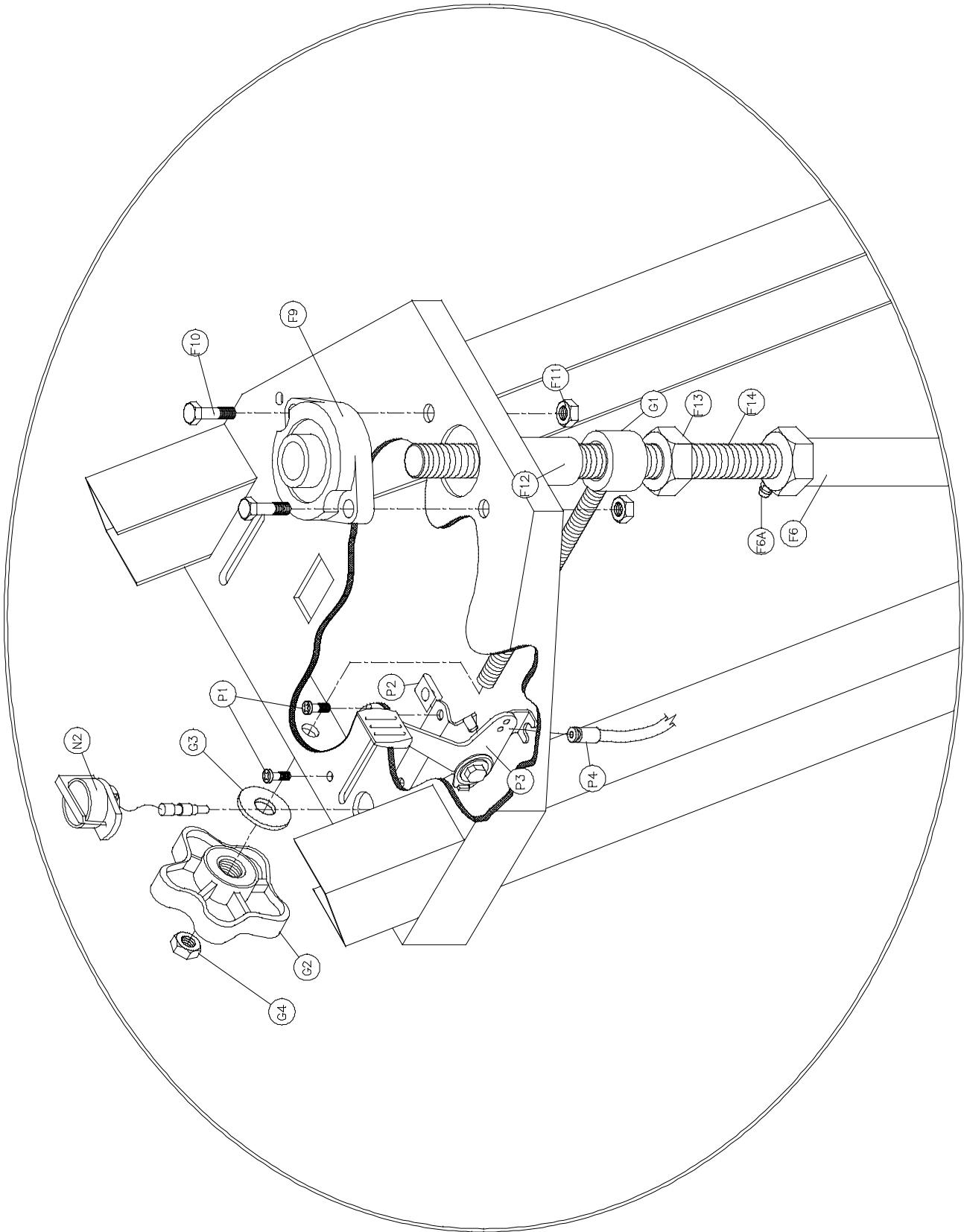

Dixie Diamond Manufacturing, Inc.
205 Buxton Court • Lilburn, Georgia 30047
Phone: 800.654.7224 or 770.921.2464
(8:00 a.m. to 7:00 p.m. Eastern Time)
Fax: 770-921-4370

SOLD AND SERVICED BY:

Part Number 159875
Rev. 06/04

WARRANTY

Dixie Diamond warrants all products manufactured by it against defects in workmanship or materials for a period of one (1) year from the date of shipment to the customer.

The responsibility of Dixie Diamond under this warranty is limited to replacement or repair of defective parts at Dixie Diamond's factory, or at a point designated by it, of such part as shall appear to us upon inspection at such point, to have been defective in material or workmanship, with expense for transportation borne by the customer.

In no event shall Dixie be liable for consequential or incidental damages arising out of the failure of any product to operate properly.

Integral units such as gasoline engines, electric motors, batteries, tires, transmissions, etc. are excluded from this warranty and are subject to the prime manufacturer's warranty.

This warranty is in lieu of all other warranties. expressed or implied, and all such other warranties are hereby disclaimed.

Important: Before placing equipment in operation, record the following information.

MODEL: _____ **SERIAL NO.** _____

PURCHASE FROM: _____

ADDRESS: _____

CITY: _____ **STATE** _____ **ZIP** _____

TELEPHONE NO. _____

Before using this equipment, make sure that person using it reads and understands the instructions in this owners manual.